

Q1.

Particle 1 with charge q_1 , and particle 2 with charge q_2 are on the x-axis, with particle 1 at $x = 4.0$ cm and particle 2 at $x = -2.0$ cm. If $q_1 = 4q_2$, calculate the magnitude of the net electric force on a third particle of charge q_3 located at the origin.

- A) Zero
 - B) 12 N
 - C) 24 N
 - D) 36 N
 - E) 72 N
-

Q2.

Consider two identical conducting spheres, A and B. Sphere A carries a charge of $-12 \mu\text{C}$ and sphere B carries a charge of $+6.0 \mu\text{C}$. The spheres are touched together and then separated. What is the final charge on sphere B?

- A) $-3.0 \mu\text{C}$
 - B) $+3.0 \mu\text{C}$
 - C) Zero
 - D) $+6.0 \mu\text{C}$
 - E) $-6.0 \mu\text{C}$
-

Q3.

Four equal positive point charges are located at the corners of a square centered at the origin, their positions in the xy plane are $(1, 1)$, $(-1, 1)$, $(-1, -1)$, $(1, -1)$. The direction of the net electric field at point $(0, -1)$ is in the

- A) Negative y-direction
 - B) Positive x-direction
 - C) Negative x-direction
 - D) Positive y-direction
 - E) No direction (the electric field is zero at that point)
-

Q4.

An electron is initially moving with velocity $\vec{v} = 5.0 \times 10^6 \hat{i}$ (m/s). It then enters a region of electric field $\vec{E} = 2.4 \times 10^3 \hat{i}$ (N/C). What is the distance travelled by the electron in the region of the electric field before coming momentarily to rest?

- A) 3.0 cm
 - B) 4.0 cm
 - C) 1.0 cm
 - D) 5.0 cm
 - E) 6.0 cm
-

Q5.

An electric dipole consists of two equal and opposite charges of magnitude 2.0 nC and separated by a distance of 99 μm . The dipole is in a uniform electric field of magnitude 3.0×10^2 N/C which makes an angle of 25° with the dipole moment. Calculate the magnitude of torque on the dipole exerted by the field.

- A) 2.5×10^{-11} N.m
 - B) 7.5×10^{-11} N.m
 - C) 1.0×10^{-11} N.m
 - D) 6.8×10^{-11} N.m
 - E) 5.0×10^{-11} N.m
-

Q6.

Three charges are located as shown in **FIGURE 1**. The electric field lines due to these charges are also shown in the figure. The charge in the middle has a magnitude of 3 μC . What is the net charge of the three charges shown?

Fig#

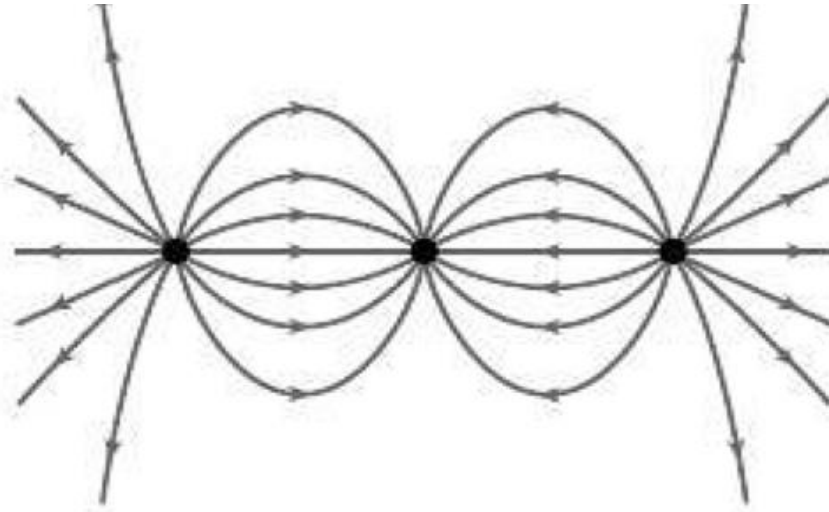

- A) $+3 \mu\text{C}$
- B) $-3 \mu\text{C}$
- C) $+2 \mu\text{C}$
- D) $-2 \mu\text{C}$
- E) $+1 \mu\text{C}$

Q7.

Two long, thin rods with linear charge densities $\lambda_1 = +6.5 \text{ nC/m}$ and $\lambda_2 = -3.5 \text{ nC/m}$, lie parallel to each other and separated by 15 cm , as shown in **FIGURE 2**. Determine the position of the point along the x -axis where the net electric field due to the two rods is zero.

Fig#

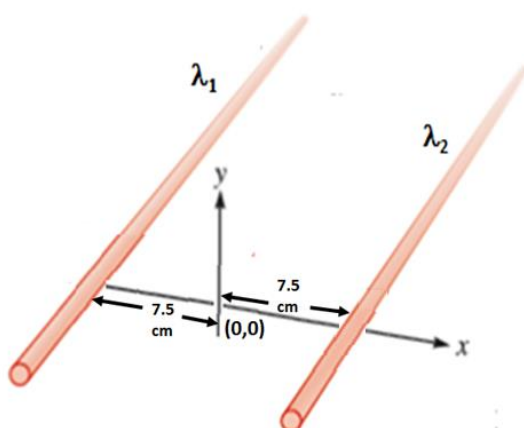

- A) $+0.25 \text{ m}$
- B) -0.25 m

- C) + 0.15 m
D) - 0.15 m
E) + 0.35 m

Q8.

A solid conducting sphere with radius $R = 5.0$ cm carries a positive charge $Q = 5.0$ nC. The sphere is surrounded by a concentric insulating shell with inner radius $R_i = 6.0$ cm and outer radius $R_o = 7.0$ cm. The insulating shell has a uniform charge density ρ . Find the value of ρ so that the net charge of the entire system (sphere and shell) is zero.

- A) $-9.4 \times 10^{-6} \text{ C/m}^3$
B) $+9.4 \times 10^{-6} \text{ C/m}^3$
C) $-5.2 \times 10^{-6} \text{ C/m}^3$
D) $+5.2 \times 10^{-6} \text{ C/m}^3$
E) $-1.7 \times 10^{-6} \text{ C/m}^3$

Q9.

Two oppositely charged large parallel conducting plates, placed close to each other (but not touching) carry uniform surface charge density σ . An electron is placed between the conducting plates, as shown in **FIGURE 3**. If the magnitude of the electric force on the electron is 1.80×10^{-15} N what is the magnitude of the surface charge density σ on each plate? (Ignore gravity effects)

Fig#

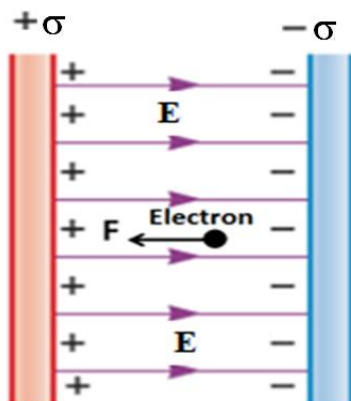

- A) 99.5 nC/m^2
B) 49.8 nC/m^2

- C) 22.1 nC/m^2
 D) 77.5 nC/m^2
 E) 66.4 nC/m^2

Q10.

A positive charge q is initially at point A in a uniform electric field E and moves to point B as shown in **FIGURE 4**. Rank the potential difference V_{AB} in following four cases, **greatest first**

- (1) if the electric field strength is doubled,
- (2) if the distance Δr was doubled,
- (3) if the points A and B were changed so the path Δr is perpendicular to the field direction,
- (4) if the positions of points A and B were interchanged?

Fig#

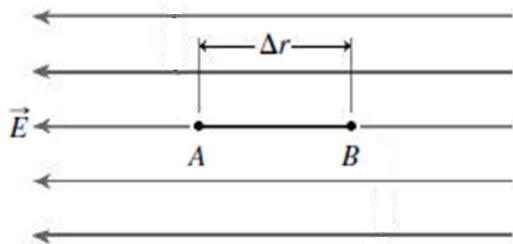

- A) 1 and 2 tie, then 3, 4
- B) 1, 3, 2, 4
- C) 2 and 3 tie, then 1, 4
- D) 4, 1, 2, 3
- E) 3 and 1 tie, then 4, 2

Q11.

Two stationary point charges $+3.00 \text{ nC}$ and $+2.00 \text{ nC}$ are separated by a distance of 50.0 cm . An electron is released from rest at a point midway between the two charges and moves along the line joining the two charges. What is the speed of the electron when it is 10.0 cm from the $+3.00 \text{ nC}$ charge?

- A) 6.89×10^6 m/s
 - B) 3.76×10^6 m/s
 - C) 1.22×10^6 m/s
 - D) 9.33×10^6 m/s
 - E) 15.5×10^6 m/s
-

Q12.

The electric potential in a region of space is given by $V(x,y,z) = x^2 + xy^2 + yz$, where x,y,z are given in meter. Determine the magnitude of electric field in this region at a point with coordinate (3m, 0, 5m).

- A) 7.81 N/C
 - B) 3.77 N/C
 - C) 11.1 N/C
 - D) 17.0 N/C
 - E) 19.5 N/C
-

Q13.

Two conducting spheres have radii of 10.0 cm and 5.00 cm, are located far away from each other. The magnitude of the electric field on the surface of each sphere is 3.60×10^3 V/m. The two spheres are then connected through a long thin conducting wire. Determine the final charge on the sphere with 10 cm radius.

- A) 3.33×10^{-9} C
 - B) 9.05×10^{-9} C
 - C) 6.45×10^{-9} C
 - D) 8.11×10^{-9} C
 - E) 1.01×10^{-9} C
-

Q14.

The capacitors in **FIGURE 5** are initially uncharged. When a potential difference $V_b - V_a = +210$ V is applied to the circuit, find the energy stored in any of 3.00 μ F capacitor.

Fig#

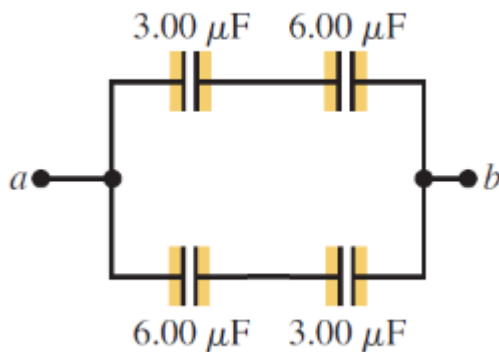

- A) 2.94×10^{-2} J
 B) 5.87×10^{-2} J
 C) 6.66×10^{-2} J
 D) 9.03×10^{-2} J
 E) 7.11×10^{-2} J

Q15.

Suppose several identical capacitors, each with capacitance $C = 90.0 \mu\text{F}$, are connected in parallel across a battery with a potential difference of 160 V. How many capacitors are needed to store 95.7 J of energy?

- A) 83
 B) 20
 C) 72
 D) 55
 E) 99

Q16.

To charge a parallel plate capacitor we connect it to a battery. After some time, while the battery is still connected to the capacitor, the distance between the capacitor plates is doubled. Which one of the following statements is **CORRECT**?

- A) The electric field between the plates is halved.

- B) The potential difference of the battery is halved.
- C) The capacitance doubles.
- D) The potential difference between the plates changes.
- E) The charge on the plates does not change.

Q17.

A dielectric with dielectric constant $\kappa = 4.0$ is inserted into a parallel plate capacitor with plate area A and plate separation d , filling $1/3$ of the volume, as shown in the **FIGURE 6**. If the capacitance of the capacitor without the dielectric is $3.0 \mu\text{F}$, what is the capacitance of the capacitor with the dielectric?

Fig#

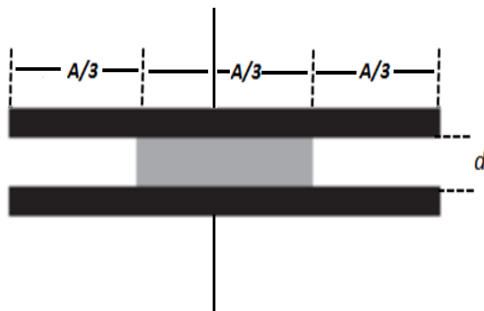

- A) $6.0 \mu\text{F}$
- B) $7.5 \mu\text{F}$
- C) $1.0 \mu\text{F}$
- D) $9.5 \mu\text{F}$
- E) $4.0 \mu\text{F}$

Q18.

Copper has 8.50×10^{28} free electrons per cubic meter. A copper wire of length 71.0 cm is 2.05 mm in diameter and carries a current of 4.85 A . How much time does it take an electron to travel the length of the wire?

- A) 110 minutes
- B) 127 minutes
- C) 133 minutes
- D) 57.0 minutes

E) 154 minutes

Q19.

At 20.0 °C a conducting rod of length 1.50 m and diameter of 0.500 cm is connected to a power supply. The power supply maintains a constant potential difference of 15.0 V across the rod ends and a current of 18.5 A. Find the rod resistivity at 20.0 °C.

- A) $1.06 \times 10^{-5} \Omega \cdot \text{m}$
 - B) $5.29 \times 10^{-5} \Omega \cdot \text{m}$
 - C) $4.05 \times 10^{-5} \Omega \cdot \text{m}$
 - D) $3.87 \times 10^{-5} \Omega \cdot \text{m}$
 - E) $2.66 \times 10^{-5} \Omega \cdot \text{m}$
-

Q20.

A 25.0 Ω bulb is connected across the terminals of 12.0 V battery having 3.50 Ω internal resistance. Find the ratio of the power of the battery that is dissipated across the internal resistance to the total power.

- A) 0.123
 - B) 0.225
 - C) 0.315
 - D) 0.420
 - E) 0.507
-