

Q1.

A neutral metal ball is suspended by a vertical string. When a positively charged insulating rod is placed near the ball (without touching), the ball is observed to be attracted to the rod. This is because:

- A) a large number of electrons accumulate on the surface of the ball facing the rod
- B) the net charge on the ball becomes positive
- C) the net charge on the ball becomes negative
- D) the number of electrons in the ball is more than the number of electrons in the rod
- E) a large number of protons accumulate on the surface of the ball facing the rod

Q2.

Three point charges are arranged as shown in **Figure 1**. Find the magnitude of the electric force on the charge at the origin.

Fig#

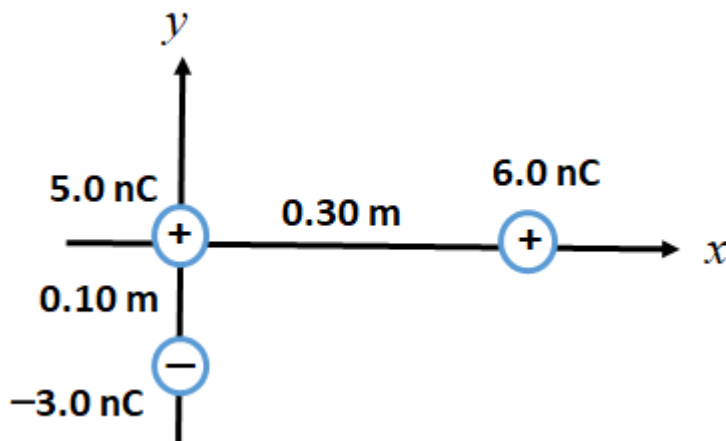

- A) $1.4 \times 10^{-5} \text{ N}$
- B) $3.0 \times 10^{-5} \text{ N}$
- C) $8.2 \times 10^{-5} \text{ N}$
- D) $2.1 \times 10^{-6} \text{ N}$
- E) $7.5 \times 10^{-5} \text{ N}$

Q3.

An isolated charged point particle produces an electric field with magnitude $1.00 \times 10^3 \text{ N/C}$ at a point 2.00 m away. At a point 1.00 m from the particle the magnitude of the field is:

- A) $4.00 \times 10^3 \text{ N/C}$
- B) $1.00 \times 10^3 \text{ N/C}$
- C) $2.00 \times 10^3 \text{ N/C}$
- D) $3.00 \times 10^3 \text{ N/C}$
- E) $5.00 \times 10^3 \text{ N/C}$

Q4.

Two point charges, $q_1 =$ charge of 4000 protons and $q_2 =$ charge of 6000 electrons, are arranged as shown in **Figure 2**. In which region could a third charge $q_3 = +1$ nC, be placed so that the net electrostatic force on it is zero?

Fig#

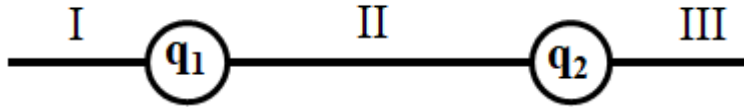

- A) I only
- B) I and II only
- C) III only
- D) I and III only
- E) II only

Q5.

A non-conducting sphere of radius 16.0 cm has a uniformly distributed charge throughout its volume. If the electric field at its surface is 360 N/C, the magnitude of electric field inside the sphere, at a point 5.00 cm from its center is:

- A) 113 N/C
- B) Zero
- C) 360 N/C
- D) 180 N/C
- E) 72.0 N/C

Q6.

An electron, initially moving with velocity $\vec{v} = (5.0 \times 10^6 \hat{i} + 5.0 \times 10^6 \hat{j})$ (m/s), enters at time $t = 0$ a region where a uniform electric field is directed along the positive x-direction. At $t = 10$ ns, the electron has a speed of 5.0×10^6 m/s. Find the magnitude of the electric field.

- A) 2.8 kN/C
- B) 1.2 kN/C
- C) 3.6 kN/C
- D) 4.1 kN/C
- E) 5.7 kN/C

Q7.

A cylindrical basket with a 0.15 m radius opening is in a uniform electric field $E = 300$ N/C, parallel to the axis of the cylinder as shown in **Figure 3**. The magnitude of the total electric flux through the side and bottom surfaces (not the top) is:

Fig#

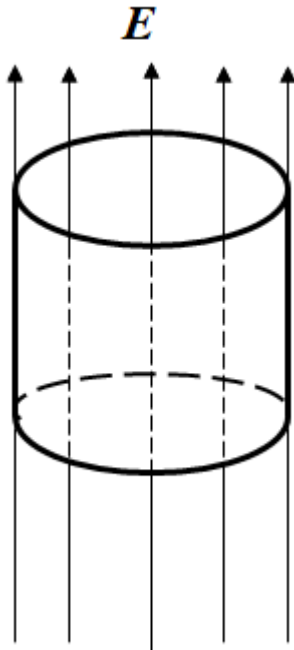

- A) $21 \text{ N}\cdot\text{m}^2/\text{C}$
- B) $4.2 \text{ N}\cdot\text{m}^2/\text{C}$
- C) zero
- D) $28 \text{ N}\cdot\text{m}^2/\text{C}$
- E) can't tell without knowing the areas of the sides

Q8.

A conducting spherical shell of inner radius 2.0 cm and outer radius 5.0 cm has surface charge density $7.5 \times 10^{-3} \text{ C/m}^2$. If $-200 \mu\text{C}$ point charge is placed at the center of the shell, find the electric field at a distance 10 cm from its center.

- A) $3.2 \times 10^7 \text{ N/C}$
- B) $1.4 \times 10^7 \text{ N/C}$
- C) $9.5 \times 10^7 \text{ N/C}$
- D) $7.1 \times 10^7 \text{ N/C}$
- E) $5.0 \times 10^7 \text{ N/C}$

Q9.

A large neutral conducting sheet is placed vertically in a 300 N/C uniform electric field in such a way that the field points perpendicularly from the sheet's left face to its right face. The surface charge density on the left and right faces of the sheet, respectively, are:

- A) $-2.7 \times 10^{-9} \text{ C/m}^2$; $+2.7 \times 10^{-9} \text{ C/m}^2$
- B) $+2.7 \times 10^{-9} \text{ C/m}^2$; $-2.7 \times 10^{-9} \text{ C/m}^2$
- C) $-5.3 \times 10^{-9} \text{ C/m}^2$; $+5.3 \times 10^{-9} \text{ C/m}^2$
- D) $+5.3 \times 10^{-9} \text{ C/m}^2$; $-5.3 \times 10^{-9} \text{ C/m}^2$
- E) 0 C/m^2 ; 0 C/m^2

Q10.

The axis of a long hollow metallic cylinder (inner radius = 1.0 cm, outer radius = 2.0 cm) coincides with a long wire. The wire has a linear charge density of -8.0 nC/m , and the cylinder has a net charge per unit length of -4.0 nC/m . Determine the magnitude of the electric field 3.0 cm from the axis of the cylinder.

- A) $7.2 \times 10^3 \text{ N/C}$
- B) $5.4 \times 10^3 \text{ N/C}$
- C) $3.8 \times 10^3 \text{ N/C}$
- D) $4.4 \times 10^3 \text{ N/C}$
- E) $6.1 \times 10^3 \text{ N/C}$

Q11.

An electron moves from point i to point f , in the direction of a uniform electric field as shown in **Figure 4**. During this motion:

Fig#

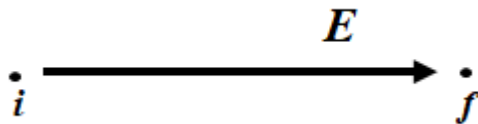

- A) the work done by the electric field is negative and the potential energy of the electron-field system increases
- B) the work done by the electric field is positive and the potential energy of the electron-field system increases
- C) the work done by the electric field is positive and the potential energy of the electron-field system decreases
- D) the work done by the electric field is negative and the potential energy of the electron-field system decreases
- E) the work done by the electric field is positive and the potential energy of the electron-field system does not change

Q12.

An electric dipole moment of magnitude $p = 3.00 \times 10^{-25} \text{ C}\cdot\text{m}$ makes an angle 60° with a uniform electric field of magnitude $E = 400 \text{ N/C}$. Find the work required to turn the electric dipole moment so that it makes 120° angle with the electric field.

- A) $+1.20 \times 10^{-22} \text{ J}$
- B) $-6.00 \times 10^{-23} \text{ J}$
- C) $+6.00 \times 10^{-23} \text{ J}$
- D) $-1.20 \times 10^{-22} \text{ J}$
- E) zero

Q13.

A charged particle $q_1 = 40 \text{ }\mu\text{C}$ moves directly toward a second charged particle $q_2 = 80 \text{ }\mu\text{C}$, which is held at a fixed position. At an instant when the distance between the two particles is

2.0 m, the kinetic energy of q_1 is 16 J. Determine the distance separating the two particles when q_1 momentarily stops.

- A) 0.95 m
- B) 0.47 m
- C) 0.63 m
- D) 0.25 m
- E) 0.14 m

Q14.

Over a certain region of space, the electric potential is given by: $V(x, y) = x^2 + y^2 - 2x$ where V is in volts and x and y are in meters. Find the magnitude of the electric field at the point P (1.0 m, 2.0 m).

- A) 4.0 N/C
- B) 9.4 N/C
- C) 6.1 N/C
- D) 7.2 N/C
- E) 5.7 N/C

Q15.

In the circuit diagram shown in **Figure 5**, the capacitance of the capacitors are $C_1 = C_2 = 45 \mu\text{F}$ and $C_3 = C_4 = 90 \mu\text{F}$. Find the potential difference between points A and B (V_{AB}) if the charge on capacitor C_1 is $60 \mu\text{C}$.

Fig#

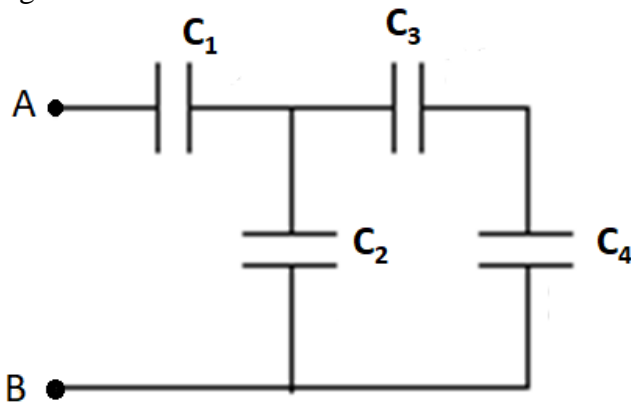

- A) 2.0 V
- B) 1.3 V
- C) 4.5 V
- D) 5.4 V
- E) 6.8 V

Q16.

A parallel-plate capacitor whose capacitance $C = 0.15 \text{ F}$ is charged by a battery to a potential difference $V = 10 \text{ V}$. The charging battery is now disconnected, and a dielectric slab ($k = 4.5$)

is inserted between the plates. Find the work done by the capacitor on the dielectric slab during this process.

- A) 5.8 J
- B) 2.7 J
- C) 3.4 J
- D) 4.2 J
- E) 6.6 J

Q17.

An air-filled parallel-plate capacitor has a capacitance of 1 pF. The plate separation is then doubled and a wax dielectric is inserted, completely filling the space between the plates. As a result, the capacitance becomes 2 pF. The dielectric constant of the wax is:

- A) 4.0
- B) 0.50
- C) 2.0
- D) 1.0
- E) 8.0

Q18.

A 3.0 μF capacitor is fully charged by a 40 V battery and a 5.0 μF capacitor is fully charged by an 18 V battery. They are disconnected from the batteries and are connected to each other, with the positive plate of each connected to the negative plate of the other. What is the final voltage across the 3.0 μF capacitor?

- A) 3.8 V
- B) 2.4 V
- C) 7.5 V
- D) 4.7 V
- E) 6.6 V

Q19.

A wire of radius 2.0×10^{-5} m and length 0.27 m has an electric field of 6.2 V/m. If the current density in the wire is 2.4×10^8 A/m², find its resistance.

- A) 5.6 Ω
- B) 1.5 Ω
- C) 3.2 Ω
- D) 4.3 Ω
- E) 7.5 Ω

Q20.

A student kept her 60 watt, 120 volt study lamp turned on continuously for 12 hours. How much charge went through it?

- A) 2.2×10^4 C
 - B) 1.5×10^4 C
 - C) 3.7×10^4 C
 - D) 4.5×10^4 C
 - E) 6.1×10^4 C
-