

Q1.

Two point charges $+q$ and $-4q$ are at $x = 0$ and L , respectively. A third charge q is to be placed such that the net force on it is zero. What is the coordinate of the third charge?

- A) $x = -L$
- B) $x = -L/3$
- C) $x = +L/3$
- D) $x = +2L/3$
- E) $x = +2L$

Q2.

Two identical neutral very small copper spheres are separated by a center to center distance of 10.0 cm. The same amount of charge is removed from each sphere. How many electrons need to be removed from each sphere for the spheres to repel each other with a force of 10.0 N?

- A) 2.08×10^{13}
- B) 3.19×10^5
- C) 1.60×10^{19}
- D) 3.60×10^{19}
- E) 4.10×10^5

Q3.

Four point charges are placed at the corners of a square, as shown in **Figure 1**. All charges have the same magnitude. If the net electric field at the center of the square is in the positive x direction, what are the signs of the charges q_1, q_2, q_3, q_4 , respectively?

Fig# 1

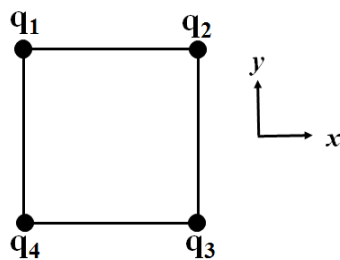

- A) $+, -, -, +$
- B) $+, +, -, -$
- C) $-, -, +, +$
- D) $-, +, +, -$
- E) $+, -, +, -$

Q4.

An electric field $\vec{E} = 100,000 \hat{i}$ (N/C) causes the 5.00 g point charge in **Figure 2** to be in equilibrium $\theta = 20.0^\circ$. What is the charge on the ball?

Fig# 2

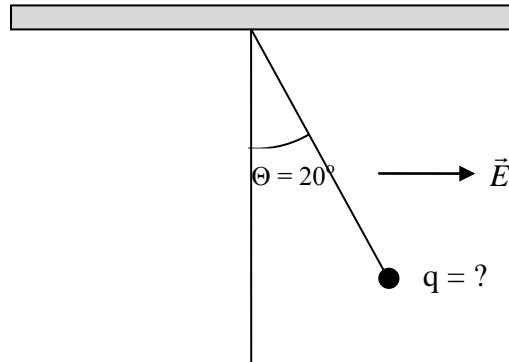

- A) 178 nC
- B) 281 nC
- C) 98.0 nC
- D) 105 nC
- E) 981 nC

Q5.

Point charges $q_1 = +5.0 \mu\text{C}$ and $q_2 = -5.0 \mu\text{C}$ are separated by 5.0 mm, forming an electric dipole. The charges are placed in a uniform electric field whose direction makes an angle of 40° with the line connecting the charges. What is the magnitude of this field if the torque exerted on the dipole has a magnitude of $7.5 \times 10^{-9} \text{ N}\cdot\text{m}$?

- A) 0.47 N/C
- B) 0.39 N/C
- C) 0.20 N/C
- D) 0.23 N/C
- E) 0.33 N/C

Q6.

You are given a large insulating object that has a uniform charge density of $2.5 \mu\text{C}/\text{m}^3$. Now imagine a sphere of radius 20 cm inside the material. What is the net flux through the surface of the sphere?

- A) $9.5 \times 10^3 \text{ Nm}^2/\text{C}$
- B) Zero
- C) $2.7 \times 10^3 \text{ Nm}^2/\text{C}$
- D) $8.1 \times 10^3 \text{ Nm}^2/\text{C}$
- E) It cannot be found since we do not know the size and shape of the object.

Q7.

Figure 3 gives the magnitude of the electric field inside and outside sphere **A** with a positive charge distributed uniformly throughout its volume. A Gaussian spherical surface **B** is concentric with sphere **A** and has a radius of 20.0 cm. What is the net flux through surface **B**?

Fig# 3

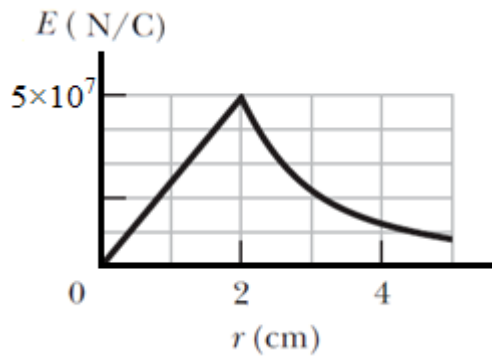

- A) $2.51 \times 10^5 \text{ Nm}^2/\text{C}$
- B) $4.22 \times 10^6 \text{ Nm}^2/\text{C}$
- C) $8.21 \times 10^4 \text{ Nm}^2/\text{C}$
- D) $3.11 \times 10^4 \text{ Nm}^2/\text{C}$
- E) Zero

Q8.

In **Figure 4**, an electron is shot directly away from a uniformly charged sheet. It moves with an acceleration of $2.86 \times 10^4 \text{ m/s}^2$. The sheet is non-conducting, flat and very large. What is the sheet's surface charge density? Ignore the gravitational force.

Fig# 4

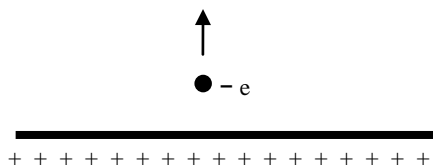

- A) $2.88 \times 10^{-18} \text{ C/m}^2$
- B) $3.85 \times 10^{-18} \text{ C/m}^2$
- C) $9.85 \times 10^{-18} \text{ C/m}^2$
- D) $18.2 \times 10^{-18} \text{ C/m}^2$
- E) $1.21 \times 10^{-18} \text{ C/m}^2$

Q9.

An infinitely long line of charge carries a uniform charge per unit length of $2.5 \times 10^{-7} \text{ C/m}$. The line is surrounded by an infinitely long conducting cylindrical shell of radius 2.0 cm. The shell carries a net linear charge density of $-2.0 \times 10^{-7} \text{ C/m}$, with the line as the axis of the shell as shown in **Figure 5**. What is the magnitude of the electric field at a distance of 1.00 cm from the line?

Fig# 5



- A) $4.5 \times 10^5 \text{ N/C}$
- B) $8.1 \times 10^5 \text{ N/C}$
- C) $9.0 \times 10^4 \text{ N/C}$
- D) $3.6 \times 10^5 \text{ N/C}$
- E) 0

Q10.

In **Figure 6**, a proton is fired with a speed of $2.00 \times 10^5 \text{ m/s}$ from the midpoint of the two parallel plates toward the right plate. The proton does not reach the right plate, and returns as shown in the Figure. What is the proton's speed as it collides with the left plate? Ignore the gravitational force.

Fig# 6

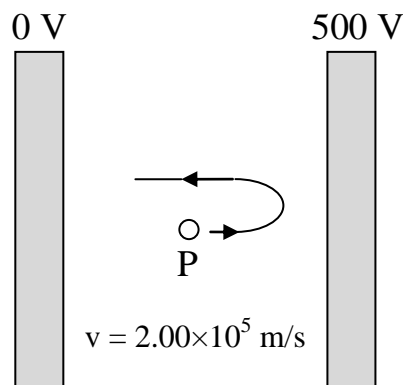

- A) $2.96 \times 10^5 \text{ m/s}$
- B) $2.00 \times 10^5 \text{ m/s}$
- C) 0
- D) $8.18 \times 10^5 \text{ m/s}$
- E) $1.41 \times 10^5 \text{ m/s}$

Q11.

A point charge $q_1 = -2.5 \mu\text{C}$ is held at rest at the origin. A second point charge $q_2 = +4.0 \mu\text{C}$ moves from the point $(0.20, 0)$ m to the point $(0, 0.15)$ m. How much work is done by the electric force on q_2 ?

- A) + 0.15 J
- B) - 0.15 J
- C) - 1.05 J
- D) + 1.05 J
- E) 0

Q12.

A charge of 3.00×10^{-8} C lies on an isolated metal sphere of radius 20.0 cm. With $V = 0$ at infinity, what is the electric potential at a point that is 10.0 cm from the center of the sphere?

- A) 1350 V
- B) 675 V
- C) 1200 V
- D) 600 V
- E) 843 V

Q13.

In a certain region of space, the electric field points in the positive x direction. In this field, an electron is moved along the x axis from $x = 2$ m to $x = 5$ m. Which of the following statements is correct?

- A) The electric potential energy of the electron-field system increases.
 - B) The electric potential energy of the electron-field system decreases.
 - C) The electric potential energy of the electron-field system remains the same.
 - D) The electron moves to a region of higher electric potential.
 - E) The electric potential is the same everywhere.
-

Q14.

Figure 7 shows a 20 V battery and two uncharged capacitors $C_1 = 4.0 \mu\text{F}$ and $C_2 = 6.0 \mu\text{F}$. The switch is thrown to the left side until capacitor 1 is fully charged. Then, the switch is thrown to the right. What is the final charge on capacitor 1?

Fig# 7

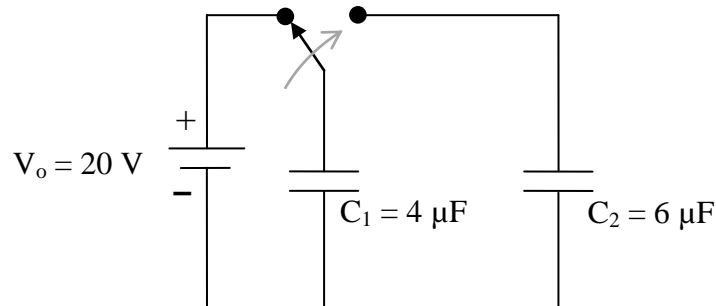

- A) $32 \mu\text{C}$
- B) $64 \mu\text{C}$
- C) $16 \mu\text{C}$
- D) $8.0 \mu\text{C}$
- E) $80 \mu\text{C}$

Q15.

Figure 8 shows three combinations of capacitors connected in series, parallel or neither. The combinations in (I), (II), and (III) respectively are

Fig# 8

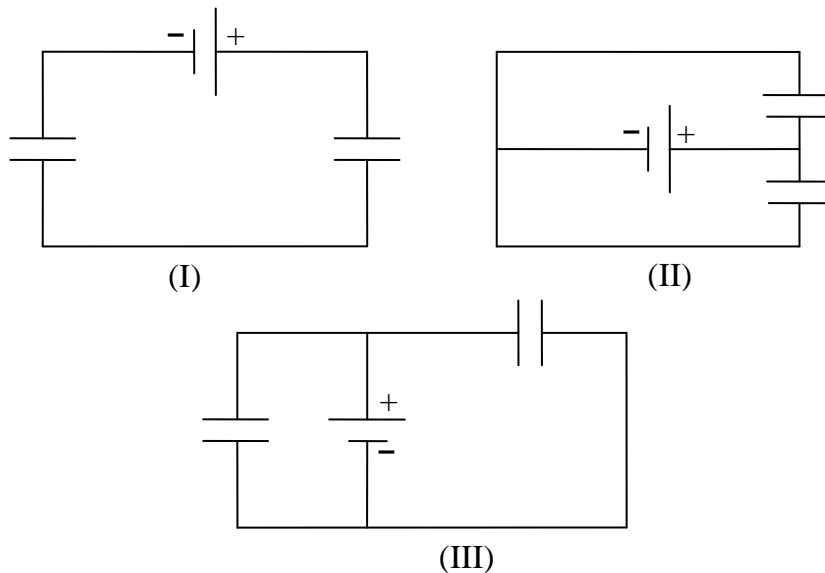

- A) series, parallel, parallel
- B) series, series, series
- C) parallel, parallel, series
- D) series, neither, neither

E) parallel, neither, neither

Q16.

Two capacitors, $C_1 = 2.00 \mu\text{F}$ and $C_2 = 5.00 \mu\text{F}$ are connected in series with a 20.0 V battery. Find the energy stored in capacitor C_1 .

- A) 204 μJ
- B) 181 μJ
- C) 490 μJ
- D) 137 μJ
- E) 253 μJ

Q17.

A parallel plate capacitor with a dielectric sheet inserted between its plates has a capacitance of 50 pF. If the plate separation is 0.10 mm, find the maximum operating potential difference. (For the dielectric: dielectric constant = 6.0, dielectric strength = $150 \times 10^6 \text{ V/m}$).

- A) 15 kV
- B) 230 kV
- C) 88 kV
- D) 21 kV
- E) 210 kV

Q18.

The heating element of a heater is rated at 1000 W when operating at 120 V. What would its power consumption be if operating at 110 V? Assume that the resistance remains constant.

- A) 840 W
- B) 1000 W
- C) 220 W
- D) 110 W
- E) 1200 W

Q19.

A 120 V potential difference is applied to a heater. There are 2.6×10^{19} electrons flowing through any cross section of the heater every second. How much energy is consumed by the heater every hour?

- A) 1.8 MJ
- B) 2.5 MJ
- C) 5.1 MJ
- D) 2.1 MJ
- E) 8.5 MJ

Q20.

Figure 9 gives the electric potential $V(x)$ versus position x along a copper wire carrying current. The wire consists of three sections (A, B, C) that differ in radius. Rank the sections according to the magnitude of the current density, greatest first.

Fig#

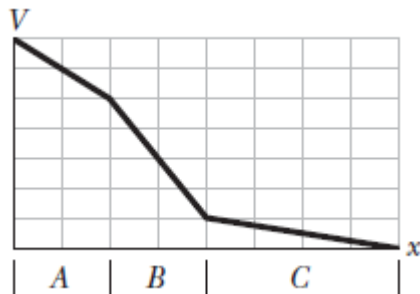

- A) B, A, C
- B) C, B, A
- C) C, A, B
- D) A, B, C
- E) A, C, B