

Q1.

What is the third lowest frequency for standing waves on a wire that is 5.0 m long, has a mass of 50 g, and is stretched under a tension of 25 N?

- A) 15 Hz
- B) 10 Hz
- C) 7.5 Hz
- D) 20 Hz
- E) 25 Hz

Q2.

A wave on a string is described by $y(x,t) = 15.0 \sin(\pi x/8 - 4\pi t)$ where x and y are in centimeter and t in seconds. What is the transverse speed for a point on the string at $x = 6.00$ cm when $t = 0.250$ s?

- A) 1.33 m/s
- B) 0.956 m/s
- C) 2.56 m/s
- D) 1.88 m/s
- E) 4.56 m/s

Q3.

A siren emitting a sound of frequency 800 Hz moves away from a stationary observer toward a cliff at a speed of 30.0 m/s. What is the frequency of the sound reflected off the cliff heard by the observer?

- A) 877 Hz
- B) 901 Hz
- C) 989 Hz
- D) 220 Hz
- E) 533 Hz

Q4.

FIGURE 1 shows the PV diagram of a series of processes. In process ab , 150 J of heat is added to the system and in process bd , 600 J of heat is added. Find the change in internal energy for the process abd .

Fig#

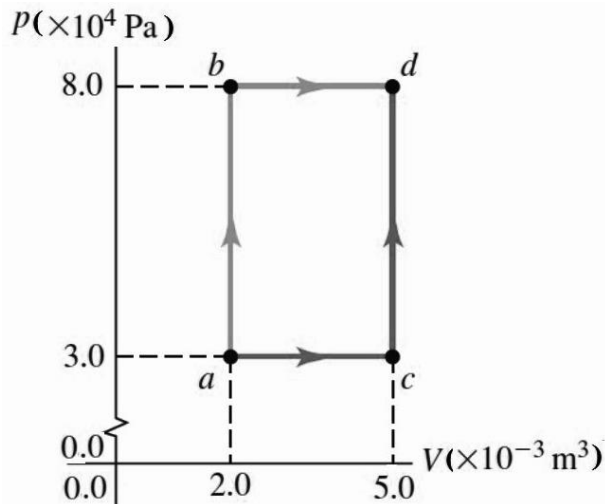

- A) +510 J
 B) -510 J
 C) +240 J
 D) -240 J
 E) +111 J

Q5.

A 10 g ice cube at 0.0 °C is added to 40 g of water at 30 °C. After enough time has passed to allow the ice cube and water to come to equilibrium, find the equilibrium temperature of ice-water mixture.

- A) 8.1 °C
 B) 2.5 °C
 C) 21 °C
 D) 15 °C
 E) 19 °C

Q6.

A thermally insulated box filled with an ideal monatomic gas undergoes a sudden free expansion from volume V_1 to volume V_2 . Only one of the following statements CORRECTLY describes this process?

- A) The internal energy of the gas remains constant.
 B) The internal energy of the gas increases.
 C) The internal energy of the gas decreases.
 D) Heat is added to the box.
 E) Heat is removed from the box.

Q7.

A Carnot heat engine uses a large hot reservoir at 100°C and a large cold reservoir at 0.00 °C. The heat rejected by the engine melts 25.0 g of ice at 0.00°C in each cycle. How much work W is performed by the engine in each cycle?

- A) 3.05×10^3 J
 B) 4.89×10^3 J
 C) 2.11×10^3 J
 D) 6.00×10^3 J
 E) 5.33×10^3 J

Q8.

The magnitude of the electrostatic force between two identical ions separated by a distance of 5.0×10^{-10} m is 3.7×10^{-9} N. How many electrons are missing from each ion?

- A) 2
 B) 4
 C) 6
 D) 8
 E) 1

Q9.

FIGURE 2 shows a charged ball of mass $m = 1.0$ g and charge $q = -2.4 \times 10^{-8}$ C suspended by a massless string in the presence of a uniform electric field \vec{E} . In this field, the ball is in equilibrium at $\theta = 37^\circ$. Calculate the magnitude of the electric field \vec{E} .

Fig#

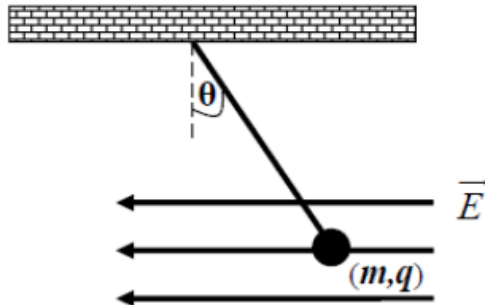

- A) 3.1×10^5 N/C
 B) 4.0×10^5 N/C
 C) 1.5×10^5 N/C
 D) 10×10^5 N/C
 E) 5.0×10^5 N/C

Q10.

A solid insulating sphere of radius 5 cm carries an electric charge uniformly distributed throughout its volume. Concentric with the sphere is a conducting spherical shell with no net charge as shown in **FIGURE 3**. The inner radius of the shell is 10 cm, and the outer radius is 15 cm. No other charges are nearby. Rank the magnitude of the electric field at points A (at radius 4 cm), B (radius 8 cm), C (radius 12 cm), and D (radius 16 cm) from largest to smallest.

Fig#

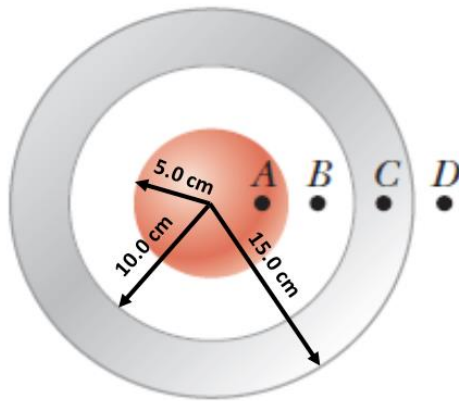

- A) A, B, D then C
 B) B, D, C then A
 C) D, C, A then B
 D) C, B, D then A
 E) B, A, C then D

Q11.

Two charges Q and $2Q$ are fixed on the corners of a square with edge length d , as shown in **FIGURE 4**. Rank the electric potentials at the three points A, B, and C due to the two charges, from largest to smallest.

Fig#

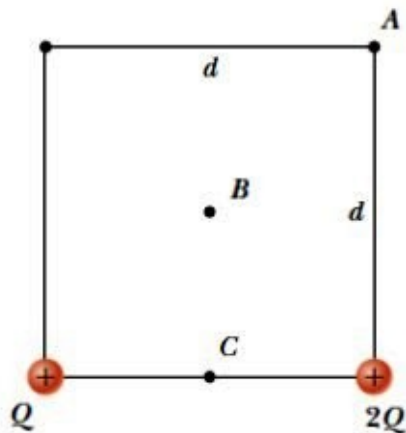

- A) C, B, A
 B) A, B, C
 C) B, C, A
 D) C, A, B
 E) A, C, B

Q12.

Two identical spherical drops of mercury each with a charge of 0.10 nC and a potential of $3.0 \times 10^2 \text{ V}$ at the surface, merge to form a single spherical drop. What is the electric potential at the surface of the new drop?

- A) 4.8×10^2 V
 B) 0.24×10^2 V
 C) 1.6×10^2 V
 D) 3.9×10^2 V
 E) 7.8×10^2 V

Q13.

A group of identical capacitors are connected first in series and then in parallel. The combined capacitance in parallel is 100 times larger than for the series connection. How many capacitors are in the group?

- A) 10
 B) 1000
 C) 100
 D) 20
 E) 50

Q14.

An air-filled parallel-plate capacitor has a capacitance of 1.3 pF. The separation of the plates is doubled, and a dielectric material (wax) is inserted between them. The new capacitance is 2.9 pF. Find the dielectric constant of the wax.

- A) 4.5
 B) 1.7
 C) 2.5
 D) 3.2
 E) 1.1

Q15.

Identical batteries are connected in three different arrangements to the same light bulb as shown in the **FIGURE 5**. Assume that the batteries have no internal resistance. Rank the arrangements according to the current flowing through the bulb, **greatest first**.

Fig#

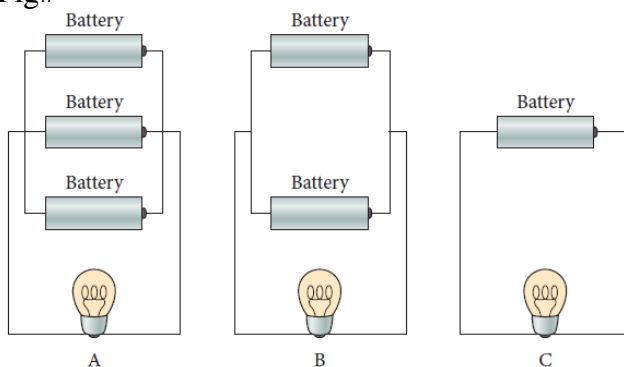

- A) All tie.
 B) A, B, C
 C) C, B, A

- D) A, C, B
E) C, A, B

Q16.

In **FIGURE 6**, find the equivalent resistance between points a and b .

Fig#

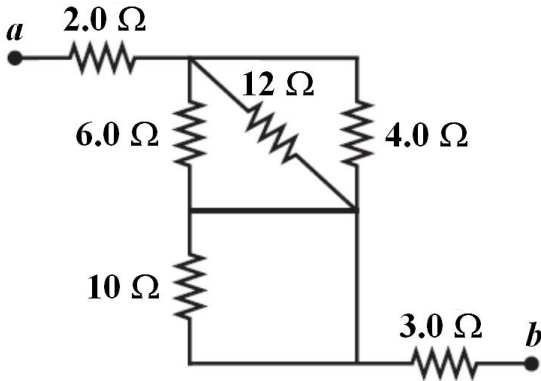

- A) 7.0 Ω
B) 10 Ω
C) 45 Ω
D) 40 Ω
E) 17 Ω

Q17.

In the circuit shown in **FIGURE 7**, if the current in 2.0 Ω resistor is 3.0 A, then find the value of unknown battery emf, \mathcal{E} .

Fig#

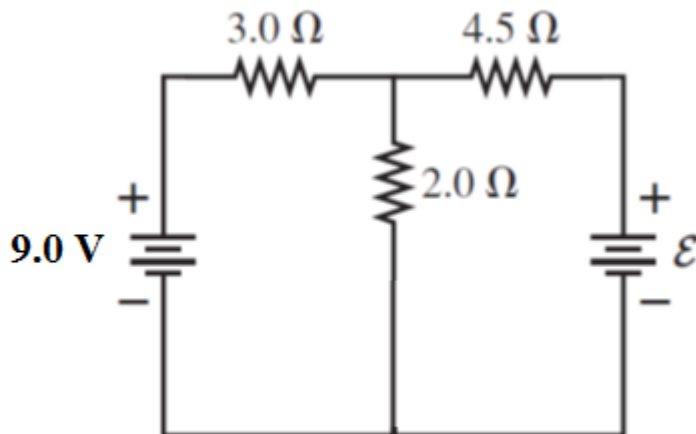

- A) 15 V
B) 10 V
C) 5.0 V
D) 9.0 V
E) 3.0 V

Q18.

In the section of a circuit shown in **FIGURE 8**, $V_b - V_a = 4.00$ V, find the magnitude and direction of current in 2.00Ω resistor.

Fig#

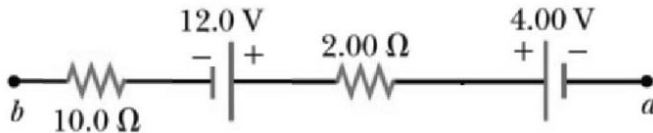

- A) 1.00 A, towards the right
- B) 1.00 A, towards the left
- C) 2.55 A, towards the right
- D) 2.55 A, towards the left
- E) 3.05 A, towards the right

Sec# Measurement - What is Physics
Grade# 55

Q19.

If the capacitor in an RC circuit is replaced by two identical capacitors connected in series, then find the CORRECT statement.

- A) The time constant will decrease by a factor of 2
- B) The time constant will be doubled
- C) The time constant will be unchanged
- D) The time constant will be tripled
- E) The time constant will decrease by a factor of 4

Q20.

The bent current carrying wire shown in **FIGURE 9** lies in a uniform magnetic field. Each straight wire section is 3.0 m long and makes an angle $\theta = 60^\circ$ with the x -axis, and the wire carries a current of 4.0 A. What is the net magnetic force on the wire in unit vector notation if the magnetic field is given by $4.0 \hat{k}$ T?

Fig#

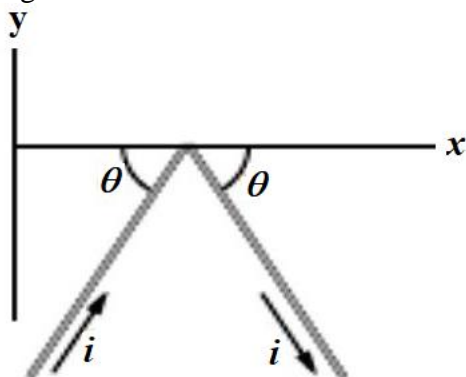

- A) $-48 \hat{j}$ N
- B) $+48 \hat{j}$ N

- C) $-24 \hat{j}$ N
 D) $+24 \hat{j}$ N
 E) $-12 \hat{j}$ N

Q21.

A proton enters into a region of uniform magnetic field \vec{B} , goes through half a circle, and then exit that region as shown in **FIGURE 10**. It spends 1.0×10^{-7} s in the magnetic field region. What is the magnitude of the magnetic field?

Fig#

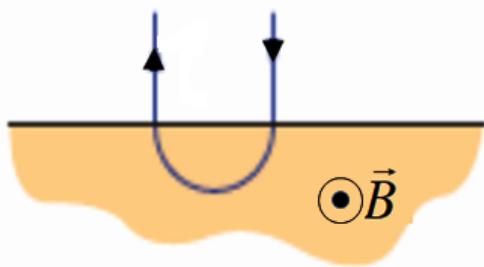

- A) 0.33 T
 B) 0.66 T
 C) 1.3 T
 D) 0.10 T
 E) 0.99 T

Q22.

The coil in **FIGURE 11** carries a current $i = 2.0$ A in the direction indicated, has 3.0 turns and a cross section area of 4.0×10^{-3} m², and lies in a uniform magnetic field $\vec{B} = (2.0 \hat{i} - 3.0 \hat{j} - 4.0 \hat{k}) \times 10^{-3}$ T. What is the torque (in unit-vector notation) on the coil due to the magnetic field?

Fig#

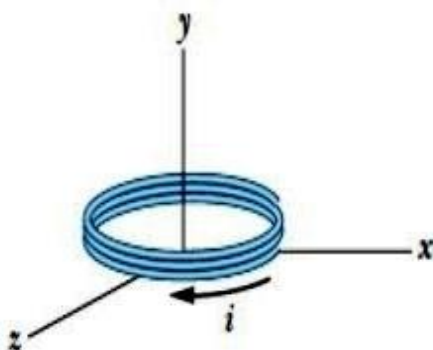

- A) $(96 \hat{i} + 48 \hat{k}) \times 10^{-6}$ N.m
 B) $(45 \hat{i} + 62 \hat{k}) \times 10^{-6}$ N.m
 C) $(23 \hat{i} + 40 \hat{k}) \times 10^{-6}$ N.m

D) $(10 \hat{i} + 8.0 \hat{k}) 10^{-6} \text{ N}\cdot\text{m}$

E) $(45 \hat{i} + 72 \hat{k}) 10^{-6} \text{ N}\cdot\text{m}$

Q23.

FIGURE 12 shows four possible orientations of a magnetic dipole moment $\vec{\mu}$ in the same magnetic field \vec{B} at angle θ . Rank the value of the orientations energy U of the magnetic dipole in the four cases, greatest first.

Fig#

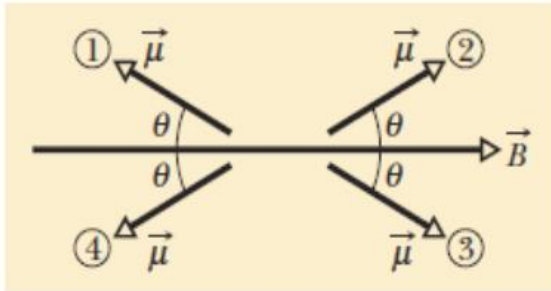

- A) 1 and 4 tie, then 2 and 3 tie
 B) All tie
 C) 1 and 2 tie, then 3 and 4 tie
 D) 1 and 3 tie, then 2 and 4 tie
 E) 2, 4, 1, 3

Q24.

FIGURE 13 shows two wires, carrying currents i_1 and i_2 , respectively. Wire 1 consists of a circular arc of radius R and two radial lengths; it carries current $i_1 = 1.8 \text{ A}$ in the direction indicated. Wire 2 is a long and straight wire, located at a distance $R/2$ from the center P of the arc, and carries a current $i_2 = 0.45 \text{ A}$. If the net magnetic field B due to the two currents at P is zero, find the angle ϕ subtended by the arc?

Fig#

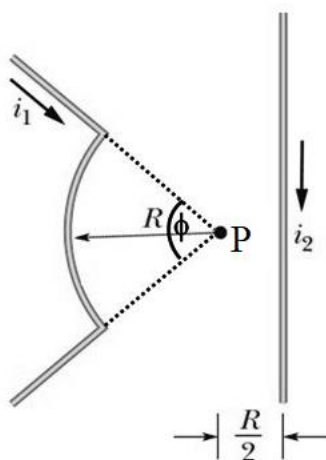

- A) 57°
 B) 66°

- C) 49°
 D) 71°
 E) 47°

Q25.

Three long identical wires are parallel to z axis, and each carries a current of 10 A in the positive z direction. Their points of intersection with the xy plane form an equilateral triangle with sides of 50 cm, as shown in **FIGURE 14**. A fourth wire (wire b) passes through the midpoint of the base of the triangle and is parallel to the other three wires. If the net magnetic force on wire a is zero, what are the magnitude and direction of the current in wire b ?

Fig#

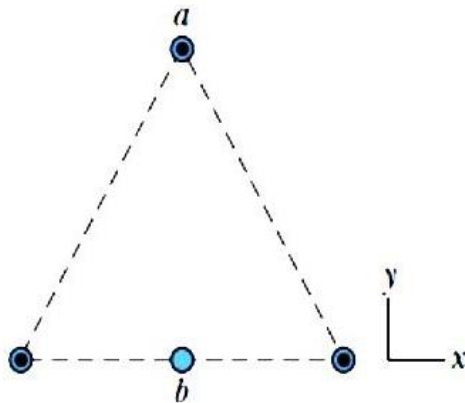

- A) 15 A, along $-z$ axis
 B) 15 A, along $+z$ axis
 C) 9.5 A, along $-z$ axis
 D) 9.5 A, along $+z$ axis
 E) 12 A, along $-z$ axis

Q26.

Eight wires cut the page perpendicularly at the points shown in **FIGURE 15**. All wires labeled with the integer k ($k= 1, 2, \dots, 8$) carry the same current of 2.0 A. For those wires with odd k , the current is out of the page; for those with even k , it is into the page. Evaluate the integral $\oint \vec{B} \cdot d\vec{s}$ along the closed path in the direction shown.

Fig#

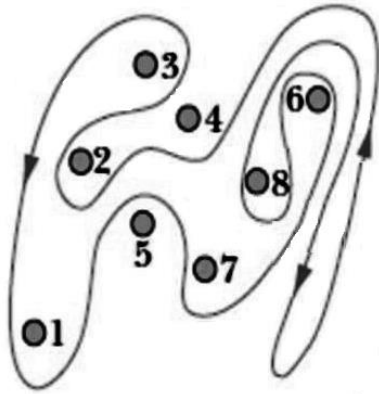

- A) $+5.0 \times 10^{-6}$ T.m
 B) -5.0×10^{-6} T.m
 C) $+7.5 \times 10^{-6}$ T.m
 D) $+0.30 \times 10^{-6}$ T.m
 E) -0.30×10^{-6} T.m

Q27.

A 40.0 cm long solenoid is designed to produce a magnetic field of 27.0×10^{-3} T at its center. If the solenoid wire can carry a maximum current of 12.0 A, what total number of turns of solenoid are required?

- A) 716
 B) 522
 C) 303
 D) 884
 E) 174

Q28.

Two rectangular loops of wire lie in the same plane as shown in **FIGURE 16**. If the current I in the outer loop is counterclockwise and increases with time, which of the following statements describe the situation correctly?

Fig#



- A) The current induced in the inner loop is clockwise.
 B) The current induced in the inner loop is zero.
 C) The current induced in the inner loop is counterclockwise.
 D) The magnitude of current induced in the inner loop does not depend on the area of the loop.
 E) The direction of current induced in the inner loop depends on the area of the inner loop.

Q29.

A coil formed by wrapping 1.0×10^2 turns of wire in the shape of a square is positioned in a uniform magnetic field so that the normal to the plane of the coil makes an angle of 31° with the direction of the field. When the magnetic field is increased at a constant rate from 0.20 T to 0.60 T in 0.40 s, an emf of magnitude 0.12 V is induced in the coil. What is the total length of the wire in the coil?

- A) 15 m
- B) 11 m
- C) 19 m
- D) 14 m
- E) 7.5 m

Q30.

As shown in **FIGURE 17** a conducting bar sliding at a constant speed v (in a uniform magnetic field B_{in}) along two conducting rails under the action of an applied force of magnitude F_1 requires an input power P_1 . If the applied force is increased so that the constant speed of the bar is doubled to $2v$, what are the new applied force and the new power input?

Fig#

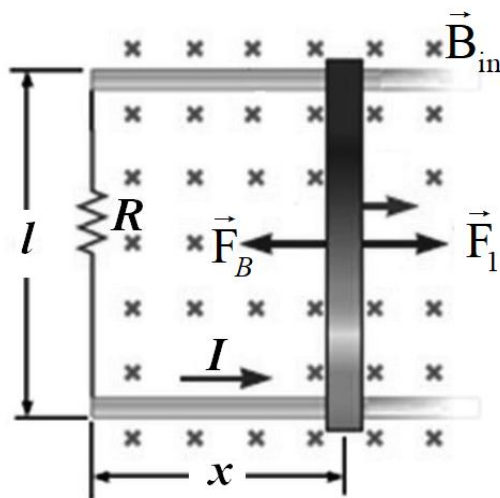

- A) $2F_1$ and $4P_1$
- B) $2F_1$ and $2P_1$
- C) $4F_1$ and $2P_1$
- D) $2F_1$ and $3P_1$
- E) $4F_1$ and $4P_1$
