

Q1.

A 125 cm long string has a mass of 2.00 g and a tension of 7.00 N. Find the lowest resonant frequency of the string.

- A) 26.5 Hz
- B) 53.0 Hz
- C) 12.4 Hz
- D) 78.5 Hz
- E) 42.0 Hz

Q2.

The intensity of sound from an isotropic point source at distance x is I . Without changing the frequency, the displacement amplitude of the sound wave from the point source is doubled. Find the intensity of the sound wave at distance $x/2.0$ from the point source in terms of I .

- A) 16 I
- B) 8.0 I
- C) 4.0 I
- D) I
- E) 2.0 I

Q3.

Two insulated identical bars made of lead (Pb) and silver (Ag) are wedges between the walls of hot and cold reservoirs, in series and in parallel, as shown in the **FIGURE 1**. If the thermal conductivity of the silver is 12.0 times that of the lead, find the ratio of conduction rate of the parallel arrangement P_p to the conduction rate in the series arrangement P_s (P_p/P_s).

Fig#

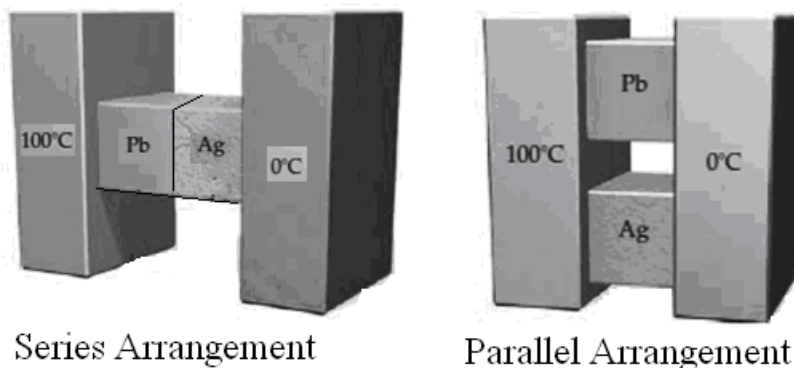

- A) 14.1
- B) 12.0
- C) 13.2
- D) 11.7
- E) 17.3

Q4.

2.00 moles of an ideal monoatomic gas expand adiabatically from an initial temperature of 300 °C to a final temperature of 200°C. Find the work done by the gas during the adiabatic process.

- A) $+2.50 \times 10^3$ J
- B) -2.50×10^3 J
- C) $+4.20 \times 10^3$ J
- D) $+3.50 \times 10^3$ J
- E) -4.20×10^3 J

Q5.

A massless cup holding 125 g of hot water at 100 °C cools to a room temperature of 20.0 °C. What is the change in entropy of the room-water system? (Neglect any change in the room temperature)

- A) +16.6 J/K
- B) -12.6 J/K
- C) +14.3 J/K
- D) -9.25 J/K
- E) +21.2 J/K

Q6.

Two point charges of +6.0 μC and + 12 μC are held fixed on an x axis, at 4.0 cm and 8.0 cm mark, respectively. A particle with a charge of +3.0 μC is released from rest at $x = 0.0$ cm. If the initial acceleration of the particle has a magnitude of 100 km/s², what is the particle's mass?

- A) 1.52×10^{-3} Kg
- B) 9.12×10^{-3} Kg
- C) 4.05×10^{-3} Kg
- D) 3.54×10^{-3} Kg
- E) 7.42×10^{-3} Kg

Q7.

An electron enters a region with uniform electric field $\vec{E} = -2.0 \times 10^3 \hat{j} \text{ N/C}$ with an initial velocity $\vec{v} = 1.0 \times 10^6 \hat{i} \text{ m/s}$ (perpendicular to the electric field). In unit vector notation what is the velocity of the electron after 10 ns? (Ignore the effect of gravity)

- A) $(1.0 \times 10^6 \hat{i} + 3.5 \times 10^6 \hat{j}) \text{ m/s}$
- B) $(1.0 \times 10^6 \hat{i} - 3.5 \times 10^6 \hat{j}) \text{ m/s}$
- C) $(4.5 \times 10^6 \hat{i} + 3.5 \times 10^6 \hat{j}) \text{ m/s}$
- D) $(4.5 \times 10^6 \hat{i} - 3.5 \times 10^6 \hat{j}) \text{ m/s}$
- E) $(3.5 \times 10^6 \hat{i} + 3.5 \times 10^6 \hat{j}) \text{ m/s}$

Q8.

A point charge $q = -6.0 \mu\text{C}$ is placed at the center of a initially charged conducting spherical shell. The net electric flux through a closed surface enclosing the conducting shell is $+2.0 \times 10^6 \text{ N}\cdot\text{m}^2/\text{C}$. What is the initial charge on the shell?

- A) $23.7 \mu\text{C}$
- B) $17.7 \mu\text{C}$
- C) $11.7 \mu\text{C}$
- D) $6.00 \mu\text{C}$
- E) $12.0 \mu\text{C}$

Q9.

FIGURE 2 shows the cross section of three very long rods that extends into and out of the page form an equilateral triangle. For given linear charge densities rank the electric field at the midpoint of each side a, b, and c, **GREATEST FIRST**.

Fig#

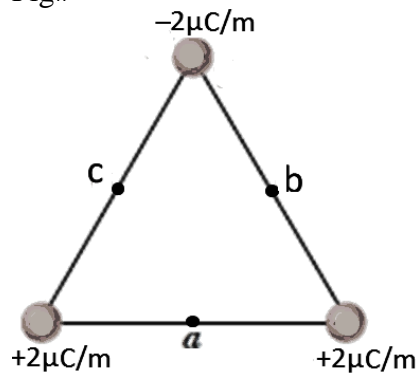

- A) b and c tie, a
- B) a, b, c
- C) a, then b and c tie
- D) b, c, a
- E) c, b, a

Q10.

Consider an isolated **point charge** $q = 1.50 \times 10^{-8} \text{ C}$. Find the distance between the two equipotential surfaces of 10.0 V and 20.0 V due to the charge q . (Assume potential is zero at infinity)

- A) 6.75 m
- B) 13.5 m
- C) 20.5 m
- D) 9.75 m
- E) 3.50 m

Q11.

An air filled parallel plate capacitor $C = 100 \mu\text{F}$ is connected to an ideal battery $V = 12.0 \text{ V}$. If each plate of the capacitor has an area of 100 cm^2 , find the surface charge density σ on the positively charged plate of the capacitor.

- A) $1.20 \times 10^{-1} \text{ C/m}^2$
- B) $1.20 \times 10^{-3} \text{ C/m}^2$
- C) $1.20 \times 10^{-5} \text{ C/m}^2$
- D) $2.40 \times 10^{-4} \text{ C/m}^2$
- E) $4.66 \times 10^{-1} \text{ C/m}^2$

Q12.

FIGURE 3 shows plots of the current i through a certain cross section of a wire at four different time intervals. Rank the intervals according to the net charge that passes through the cross section during the time intervals, **GREATEST FIRST**.

Fig#

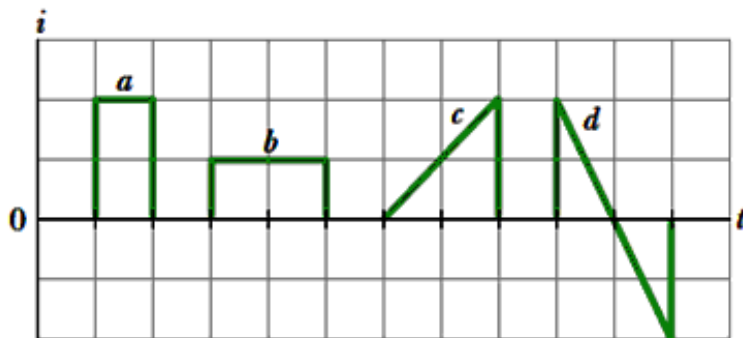

- A) a, b and c all tie, then d
- B) a and b tie, c and d tie
- C) a, b, then c and d tie
- D) a, then c and d tie, then b
- E) c, d, a, b

Q13.

In **FIGURE 4** the potential difference between point A and B ($V_B - V_A$) is 20 V . Find the current I .

Fig#

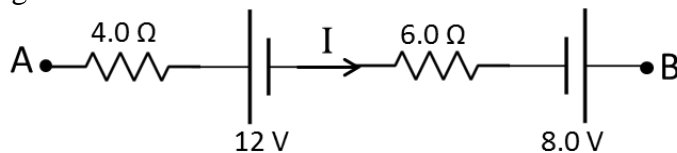

- A) -2.4 A
- B) -1.6 A
- C) $+2.0 \text{ A}$
- D) -3.6 A
- E) $+1.6 \text{ A}$

Q14.

For the circuit shown in **FIGURE 5**, rank the points according to their potentials in the circuit, **GREATEST FIRST**.

Fig#

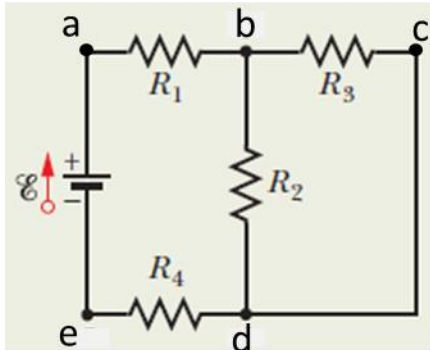

- A) a, b, then c and d tie, e
- B) a, b, c, d, e
- C) e, then d and c tie, b, a
- D) e, d, c, b, a
- E) a and b tie, c, then d and e tie

Q15.

In the circuit shown in the **FIGURE 6** the batteries have negligible internal resistance. Find the potential difference between point **a** and **b** ($V_a - V_b$).

Fig#

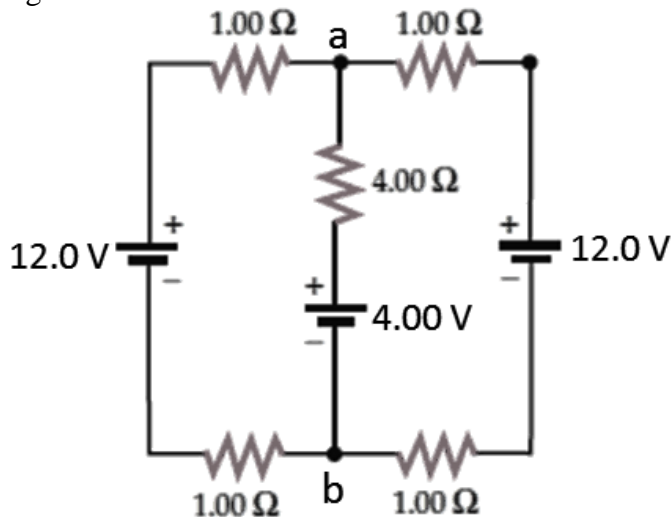

- A) 10.4 V
- B) 2.40 V
- C) 6.40 V
- D) 11.2 V
- E) 1.60 V

Q16.

The current I through the $12\ \Omega$ resistor is $0.50\ \text{A}$ in the circuit shown in **FIGURE 7**. Find the voltage across the $3.0\ \Omega$ resistor.

Fig#

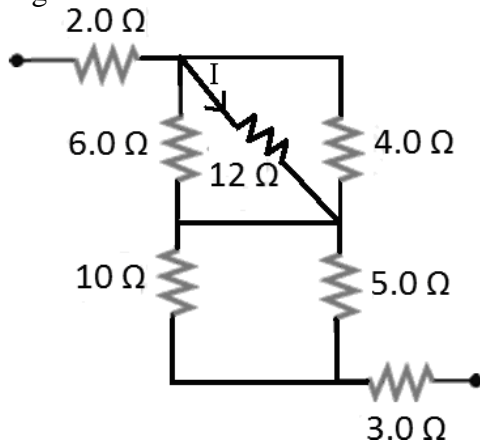

- A) 9.0 V
- B) 1.5 V
- C) 12 V
- D) 3.0 V
- E) 4.5 V

Q17.

For the circuit shown in **FIGURE 8** find the minimum (I_{\min}) and maximum (I_{\max}) value of the current in the circuit after closing the switch S . (assume the battery has negligible internal resistance).

Fig#

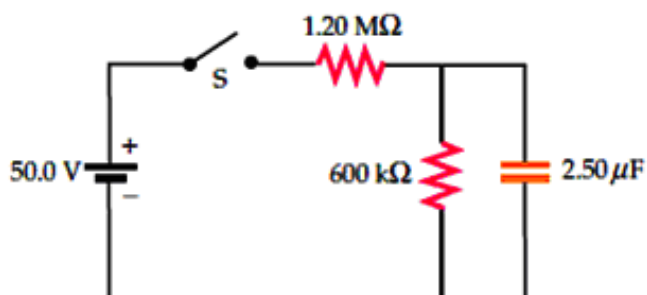

- A) $I_{\max} = 4.17 \times 10^{-5}\ \text{A}$; $I_{\min} = 2.78 \times 10^{-5}\ \text{A}$
- B) $I_{\max} = 2.78 \times 10^{-5}\ \text{A}$; $I_{\min} = 2.78 \times 10^{-5}\ \text{A}$
- C) $I_{\max} = 6.28 \times 10^{-5}\ \text{A}$; $I_{\min} = 2.78 \times 10^{-5}\ \text{A}$
- D) $I_{\max} = 5.37 \times 10^{-5}\ \text{A}$; $I_{\min} = 3.72 \times 10^{-5}\ \text{A}$
- E) $I_{\max} = 4.17 \times 10^{-5}\ \text{A}$; $I_{\min} = 4.17 \times 10^{-5}\ \text{A}$

Q18.

A negatively charged particle moving with constant speed enters along the positive y-axis in a region of uniform magnetic field, pointing into the page, as shown in **FIGURE 9**. Which of the following is true about the direction of the magnetic force \hat{F}_B , at points **a**, **b**, and **c**, on the negatively charged particle?

Fig#

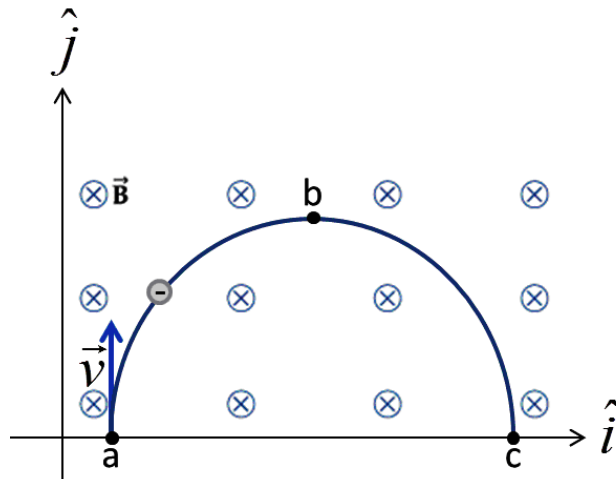

- A) $\hat{F}_{Ba} = \hat{i}$, $\hat{F}_{Bb} = -\hat{j}$, $\hat{F}_{Bc} = -\hat{i}$
 B) $\hat{F}_{Ba} = \hat{i}$, $\hat{F}_{Bb} = \hat{i}$, $\hat{F}_{Bc} = \hat{i}$
 C) $\hat{F}_{Ba} = -\hat{i}$, $\hat{F}_{Bb} = -\hat{i}$, $\hat{F}_{Bc} = -\hat{i}$
 D) $\hat{F}_{Ba} = -\hat{i}$, $\hat{F}_{Bb} = \hat{j}$, $\hat{F}_{Bc} = \hat{i}$
 E) $\hat{F}_{Ba} = \hat{i}$, $\hat{F}_{Bb} = \hat{j}$, $\hat{F}_{Bc} = \hat{i}$

Q19.

In **FIGURE 10** an electron enters horizontally the gap between two parallel plates with a speed of 1.20×10^7 m/s. The separation between the plates $d = 30.0$ mm and the potential difference is $V = 200$ V, where the lower plate is at lower potential. What uniform magnetic field between the plates allows the electron to travel in a straight line in the gap?

Fig#

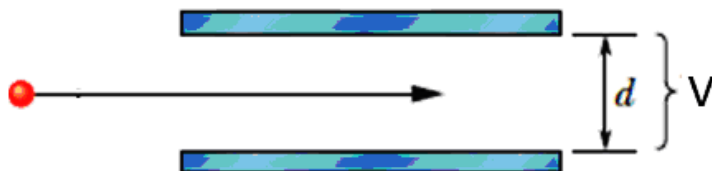

- A) 5.56×10^{-4} T into the page
 B) 5.56×10^{-4} T out of the page
 C) 5.56×10^{-6} T into the page
 D) 5.00×10^{-5} T into the page
 E) 3.45×10^{-4} T out of the page

Q20.

A wire 80.0 cm long carries a 0.820 A current in the positive direction of a y axis through a magnetic field $\vec{B} = (4.00\hat{i} + 12.0\hat{j})mT$. In unit vector notation, what is the magnetic force on the wire?

- A) $-2.62 \times 10^{-3} \hat{k} N$
- B) $+2.62 \times 10^{-3} \hat{k} N$
- C) $-2.62 \times 10^{-3} \hat{j} N$
- D) $+3.23 \times 10^{-3} \hat{i} N$
- E) $-23.4 \times 10^{-3} \hat{k} N$

Q21.

A square 12 turns coil has an edge length of 40.0 cm and carries a current of 4.00 A. The coil lies in xy plane, as shown in the **FIGURE 11** in a uniform magnetic field $\vec{B} = (0.300\hat{i} + 0.400\hat{k})T$. Find the torque exerted on the coil.

Fig#

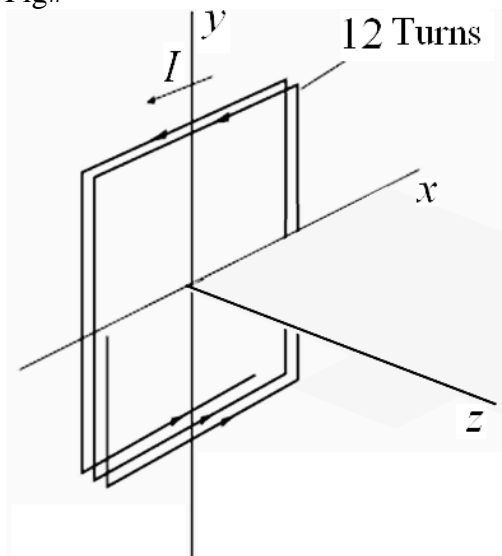

- A) $2.30 \hat{j} N.m$
- B) $4.50 \hat{k} N.m$
- C) $1.53 \hat{j} N.m$
- D) $3.21 \hat{i} N.m$
- E) $2.92 \hat{j} N.m$

Q22.

A current loop, carrying a current of 6.0 A, is in the shape of a right angle triangle with sides 30, 40, and 50 cm. The loop is in a uniform magnetic field of magnitude 120 mT whose direction is parallel to the current in the 50 cm side of the loop. Find the orientation energy of the coil in the magnetic field.

- A) Zero
- B) 8.6×10^{-2} J
- C) 4.3×10^{-2} J
- D) $9.3 \times 10^{+2}$ J
- E) $4.3 \times 10^{+2}$ J

Q23.

FIGURE 12 shows three circuits consisting of straight radial lengths and concentric circular arcs (either half or quarter circles of radius r , $2r$, and $3r$). The circuits carry the same current. Rank them according to the magnitude of the magnetic field produced at the center of arcs (the dot), **GREATEST FIRST**.

Fig#

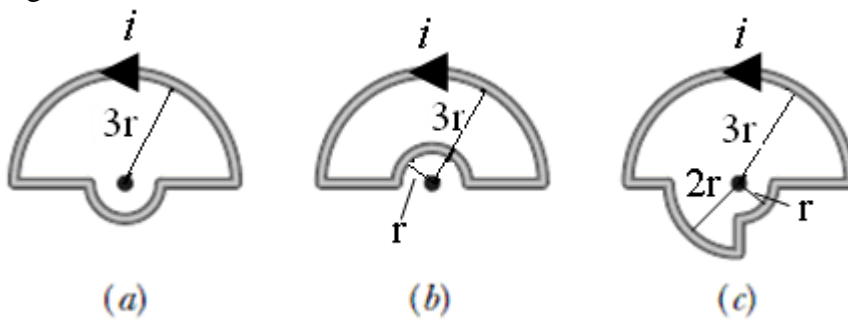

- A) a, c, b
- B) c, a, b
- C) a and b tie, c
- D) c, a and b tie
- E) c, b, a

Q24.

In **FIGURE 13** wire 1 consists of a circular arc of radius $R = 4.00$ cm and two radial lengths and carries a current $i_1 = 5.00$ A in the direction indicated. Wire 2 is a long, straight and perpendicular to the plane of the figure and carries a current $i_2 = 2.00$ A into the page. Find the magnitude of the resultant magnetic field at the center of the arc P .

Fig#

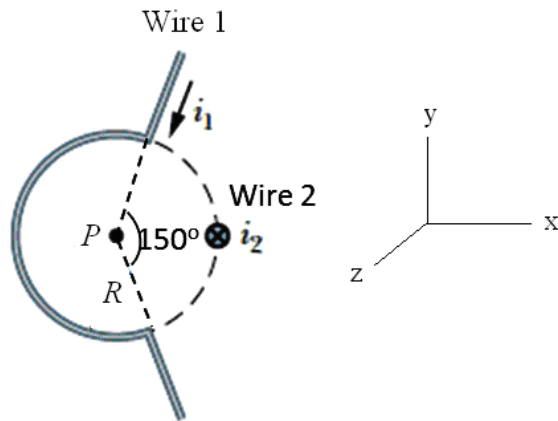

- A) $4.69 \times 10^{-5} \text{ T}$
- B) $2.04 \times 10^{-5} \text{ T}$
- C) $4.17 \times 10^{-7} \text{ T}$
- D) $3.42 \times 10^{-5} \text{ T}$
- E) $3.15 \times 10^{-7} \text{ T}$

Q25.

Five long, parallel straight wires are placed perpendicular to the plane of the paper at the same separation of 6.00 cm and carry currents in different directions, as shown in **FIGURE 14**. The current through each of the wires **a**, **b** and **e** is 15.0 A. The Current through each of the wires **c** and **d** is 10.0 A. Find the magnitude of the net force per unit length on the wire **c**

Fig#

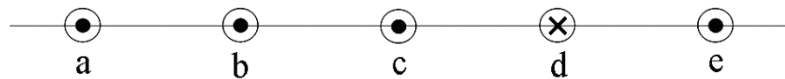

- A) $8.33 \times 10^{-4} \text{ N}$
- B) $4.17 \times 10^{-4} \text{ N}$
- C) $15.7 \times 10^{-4} \text{ N}$
- D) $2.17 \times 10^{-4} \text{ N}$
- E) $9.43 \times 10^{-5} \text{ N}$

Q26.

FIGURE 15 shows a cross section across a diameter of a long cylindrical conductor of radius of 3.0 cm carrying a uniform current 1.5×10^2 A. What is the magnitude of the magnetic field at point P, at a radial distance of 2.0 cm from the center?

Fig#

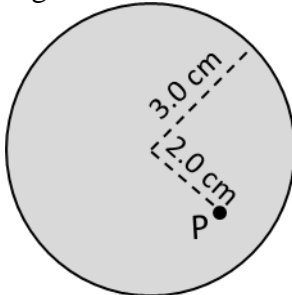

- A) 6.7×10^{-4} T
- B) 1.5×10^{-4} T
- C) 3.2×10^{-4} T
- D) 9.5×10^{-5} T
- E) 4.5×10^{-5} T

Q27.

A long solenoid has 120 turns/cm and carries current i . An electron moves within the solenoid in a circle of radius 2.50 cm perpendicular to the solenoid axis. The speed of the electron is 7.50×10^5 m/s. Find the current i in the solenoid.

- A) 1.13×10^{-2} A
- B) 5.13×10^{-2} A
- C) 2.54×10^{-2} A
- D) 3.43×10^{-2} A
- E) 7.13×10^{-2} A

Q28.

FIGURE 16 shows a 10.0 cm diameter circular loop placed in the plane of the page where out the page a magnetic field increases at a constant rate of 0.50 T/s. What is the magnitude of the induced emf and direction of the induced current?

Fig#

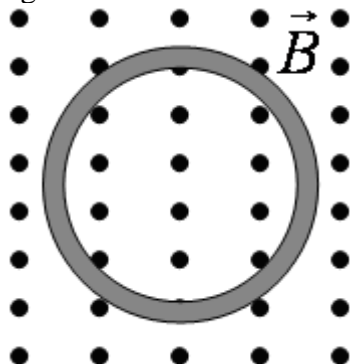

- A) 3.93 mV; clockwise

- B) 3.93 mV; counterclockwise
- C) 1.25 mV; clockwise
- D) 1.25 mV; counterclockwise
- E) 7.85 mV; counterclockwise

Q29.

A square loop of copper wire is pulled through a region of uniform magnetic field, as shown in **FIGURE 17**. Rank **GREATEST FIRST**, the pulling forces F_a , F_b , F_c , and F_d that must be applied to keep the loop moving at constant speed.

Fig#

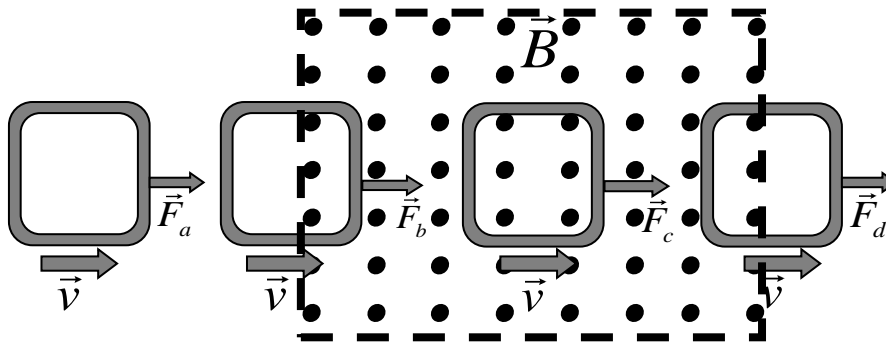

- A) F_b and F_d tie, F_a and F_c tie
- B) F_c , then F_b and F_d tie, F_a
- C) F_b , F_c , F_d , F_a
- D) F_c , F_d , F_b , F_a
- E) F_a , F_b , F_c , F_d

Q30.

A loop of antenna of area 3.50 cm^2 and resistance $6.50 \mu\Omega$ is perpendicular to a uniform magnetic field of magnitude $30.0 \mu\text{T}$. The magnitude of the magnetic field drops to zero in 2.50 ms . How much thermal energy is produced in the loop by the changing magnetic field?

- A) $2.71 \times 10^{-6} \text{ W}$
- B) $1.20 \times 10^{-6} \text{ W}$
- C) $4.71 \times 10^{-6} \text{ W}$
- D) $3.22 \times 10^{-4} \text{ W}$
- E) $7.30 \times 10^{-3} \text{ W}$