

Q1.

A string of length L vibrates in its fundamental mode. The amplitude at a point $L/4$ from one end is 2.0 cm. What is the amplitude of each traveling wave that produces this standing wave?

- A) 1.4 cm
- B) 6.7 cm
- C) 0.3 cm
- D) 5.9 cm
- E) 0.1 cm

Q2.

In **FIGURE 1** S is a small loudspeaker driven by an audio oscillator with a frequency that is varied from 500 Hz to 1400 Hz, and D is a cylindrical pipe with one-close end and a length of 75.0 cm. The speed of sound in the air-filled pipe is 343 m/s. At how many frequencies does the sound from the loudspeaker set up resonance in the pipe?

Fig#

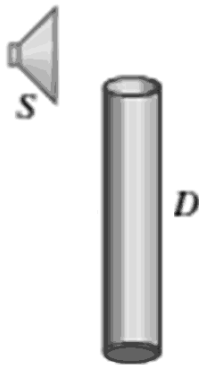

- A) 4
- B) 5
- C) 3
- D) 7
- E) 6

Q3.

A monatomic gas follows the process from points 1–2–3 as shown in **FIGURE 2**. How much heat is absorbed in the process from point 1 to point 2?

Fig#

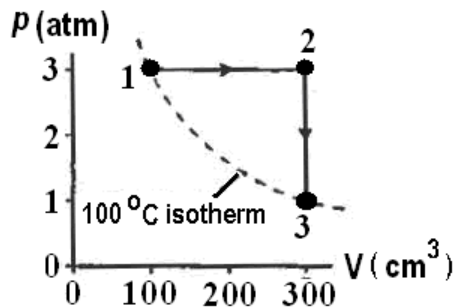

- A) 152 J
- B) 91.5 J
- C) 55.3 J
- D) 277 J
- E) 322 J

Q4.

The volume of a gas is reduced to half of its initial value during an adiabatic compression that increases the pressure by a factor of 2.50. By what factor does the temperature increase?

- A) 1.25
- B) 1.75
- C) 2.00
- D) 2.50
- E) 3.00

Q5.

A heat pump is used to absorb heat from outside a room at $7.0\text{ }^{\circ}\text{C}$ and supply the heat to the inside of the room at $27\text{ }^{\circ}\text{C}$. For each $1.5 \times 10^4\text{ J}$ of heat delivered indoors, the smallest amount of work that must be supplied to the heat pump is

- A) $1.0 \times 10^3\text{ J}$
- B) $1.5 \times 10^3\text{ J}$
- C) $1.9 \times 10^3\text{ J}$
- D) $2.0 \times 10^3\text{ J}$
- E) $2.2 \times 10^3\text{ J}$

Q6.

A charge Q_1 is positioned on the x -axis at $x = a$. Where should a charge $Q_2 = -4Q_1$ be placed to produce zero net electrostatic force on a third charge, $Q_3 = Q_1$, located at the origin.

- A) $x = 2a$
- B) $x = 0$
- C) $x = -2a$
- D) $x = -a$
- E) $x = 3a$

Q7.

A charge of 3.0 nC is placed on the y axis at $y = 3.0$ cm and a 4.0 nC charge is placed on the x axis at $x = 4.0$ cm. If both charges are held fixed, what is the magnitude of the initial acceleration of a proton which is released from rest at the origin?

- A) $3.6 \times 10^{12} \text{ m/s}^2$
- B) $4.2 \times 10^{12} \text{ m/s}^2$
- C) $1.0 \times 10^{12} \text{ m/s}^2$
- D) $7.8 \times 10^{12} \text{ m/s}^2$
- E) $9.0 \times 10^{12} \text{ m/s}^2$

Q8.

An isolated conductor of an arbitrary shape has a net charge of $+3.0 \times 10^{-6}$ C. Inside the conductor is a cavity within which is a point charge $q = +5.0 \times 10^{-6}$ C. What is the charge on the outer surface of the conductor?

- A) $+8.0 \times 10^{-6}$ C
- B) -3.0×10^{-6} C
- C) -8.0×10^{-6} C
- D) -5.0×10^{-6} C
- E) $+5.0 \times 10^{-6}$ C

Q9.

Two protons are released from rest when they are 1.0 μm apart. What is the maximum speed they will achieve?

- A) $3.7 \times 10^2 \text{ m/s}$
- B) $1.1 \times 10^2 \text{ m/s}$
- C) $2.5 \times 10^2 \text{ m/s}$
- D) $7.3 \times 10^2 \text{ m/s}$
- E) $6.7 \times 10^2 \text{ m/s}$

Q10.

In three regions of space I, II and III, where the electric field \mathbf{E} is parallel to x-axis, the electrical potential V varies as a function of distance $x(\text{cm})$, as shown in **FIGURE 3**. Rank the electrical field component E_x in the three regions, **from positive to negative**.

Fig#

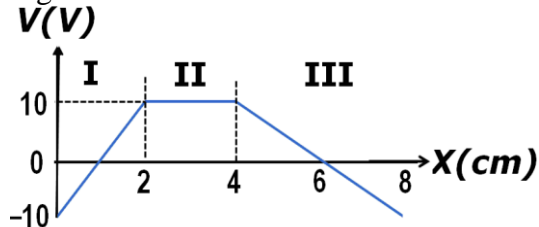

- A) III, II, I
- B) I, II, III
- C) II, III, I
- D) II, I, III
- E) III, I, II

Q11.

A capacitor with capacitance C , charged to a voltage V_0 , has initial potential energy U_0 . Then, the charged capacitor is connected in parallel with uncharged capacitor of capacitance $C/2$. Calculate the final potential energy of the two-capacitor system in units of U_0 .

- A) $2/3 U_0$
- B) $1/3 U_0$
- C) $2 U_0$
- D) $3/4 U_0$
- E) $1/2 U_0$

Q12.

Copper has 8.50×10^{28} free electrons per cubic meter. A 71.0 cm-long copper wire that is 2.05 mm in diameter, carries 4.85 A of current. How much time does it take an electron to travel the length of the wire?

- A) 110 min
- B) 200 min
- C) 55.7 min
- D) 77.3 min
- E) 165 min

Q13.

Two resistors R_1 and R_2 , with $R_1 > R_2$, are connected to a battery, first individually, then in series and then in parallel. Rank those arrangements according to the amount of current through the battery, **greatest first**.

- A) Parallel, R_2 , R_1 , series
- B) R_1 , parallel, series, R_2
- C) Series, R_1 , parallel, R_2
- D) R_2 , series, parallel, R_1
- E) R_1 , R_2 , parallel, series

Q14.

Find the potential difference between points a and b in the circuit in **FIGURE 4**, if the current in the circuit $I = 3.0$ A?

Fig#

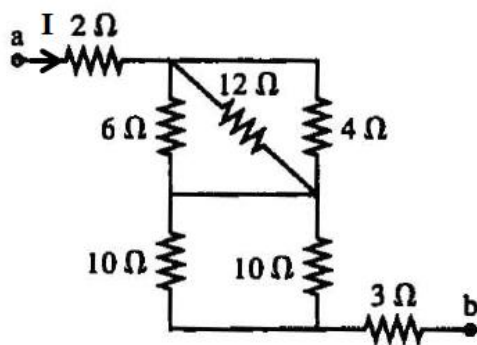

- A) 36 V
- B) 11 V
- C) 77 V
- D) 45 V
- E) 95 V

Q15.

Find the magnitude and direction of the current in the 2.0Ω resistor shown in the circuit in **FIGURE 5**.

Fig#

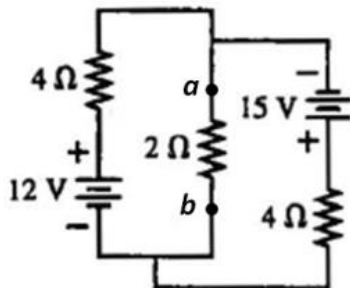

- A) 0.38 A, from *b* to *a*
- B) 1.20 A, from *a* to *b*
- C) 0.11 A, from *b* to *a*
- D) 2.30 A, from *b* to *a*
- E) 0.01 A, from *b* to *a*

Q16.

Calculate the power dissipated in the 40Ω resistor of the circuit shown in **FIGURE 6** if the potential difference across points *a* and *b* is 15 V?

Fig#

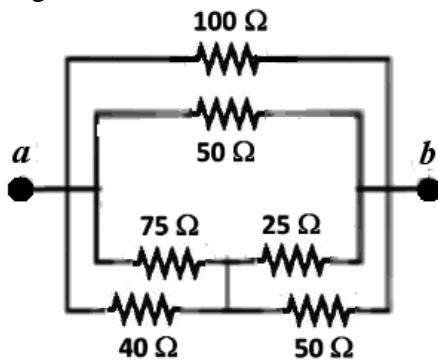

- A) 2.1 W
- B) 1.0 W
- C) 3.7 W
- D) 3.3 W
- E) 1.1 W

Q17.

A $100\ \mu\text{F}$ capacitor is charged to $50.0\ \text{V}$. It is then allowed to discharge through a $100\ \Omega$ resistor. At what time, after the discharge begins, the capacitor loses 70 % of its stored energy?

- A) $6.02 \times 10^{-3}\ \text{s}$
- B) $5.66 \times 10^{-3}\ \text{s}$
- C) $11.2 \times 10^{-3}\ \text{s}$
- D) $2.79 \times 10^{-3}\ \text{s}$
- E) $18.5 \times 10^{-3}\ \text{s}$

Q18.

An electron and a proton are moving in a magnetic field. The proton, moving with a velocity $1.50\ \text{km/s}\ \mathbf{i}$, experiences a magnetic force of $2.25 \times 10^{-16}\ \text{N}\ \mathbf{j}$. The electron, moving with a velocity of $-4.75\ \text{km/s}\ \mathbf{k}$, experiences a magnetic force of $8.50 \times 10^{-16}\ \text{N}\ \mathbf{j}$. What are the components of the magnetic field?

- A) $B_x = +1.12\ \text{T}$; $B_z = -0.94\ \text{T}$
- B) $B_x = -1.12\ \text{T}$; $B_y = +0.94\ \text{T}$
- C) $B_y = +2.45\ \text{T}$; $B_z = +1.94\ \text{T}$
- D) $B_x = -1.12\ \text{T}$; $B_z = -0.75\ \text{T}$
- E) $B_x = +0.53\ \text{T}$; $B_z = -0.55\ \text{T}$

Q19.

A particle with mass m and charge q , moving with a velocity \mathbf{v} enters a region of uniform magnetic field \mathbf{B} , as shown in **FIGURE 7**. The particle strikes the wall at a distance d from the entrance slit. If the particle's velocity stays the same but its charge to mass ratio is doubled, at what distance from the entrance slit will the particle strike the wall?

Fig#

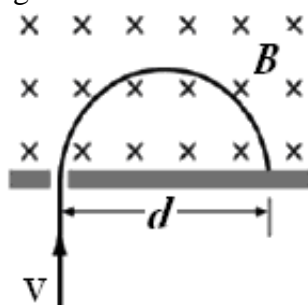

- A) $d/2$
- B) $d\sqrt{2}$
- C) d
- D) $d/\sqrt{2}$
- E) $2d$

Q20.

A 10-cm-long straight wire carrying a current of 2.0 A is located in a magnetic field \mathbf{B} . When the wire is parallel to x- axis and the current in the wire in the +x-direction, it experiences a magnetic force of $+2.4\text{ N } \mathbf{k}$. If the wire is now placed parallel to the y-axis and the current in the wire is in the + y-direction, the magnetic force on the wire becomes $-1.0\text{ N } \mathbf{k}$. Determine the magnitude of the magnetic field \mathbf{B} .

- A) 13 T
- B) 5.9 T
- C) 9.1 T
- D) 15 T
- E) 19 T

Q21.

What is the magnitude of the torque exerted by the magnetic field of the long straight wire on the current loop as shown in **FIGURE 8**?

Fig#

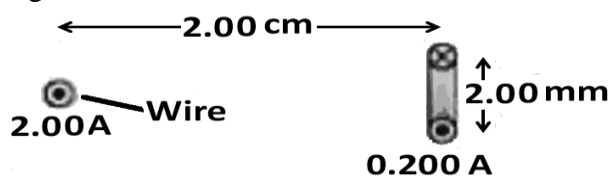

v

- A) $1.26 \times 10^{-11}\text{ N.m}$
- B) $0.26 \times 10^{-12}\text{ N.m}$
- C) $2.22 \times 10^{-12}\text{ N.m}$
- D) $3.29 \times 10^{-10}\text{ N.m}$
- E) $7.68 \times 10^{-11}\text{ N.m}$

Q22.

A long, hollow, cylindrical wire with an inner radius R and outer radius $2R$ carries a uniform current density. Which of the following graphs (**FIGURE 9**) best represents the magnitude of the magnetic field as a function of the distance from the center of the wire?

Fig#

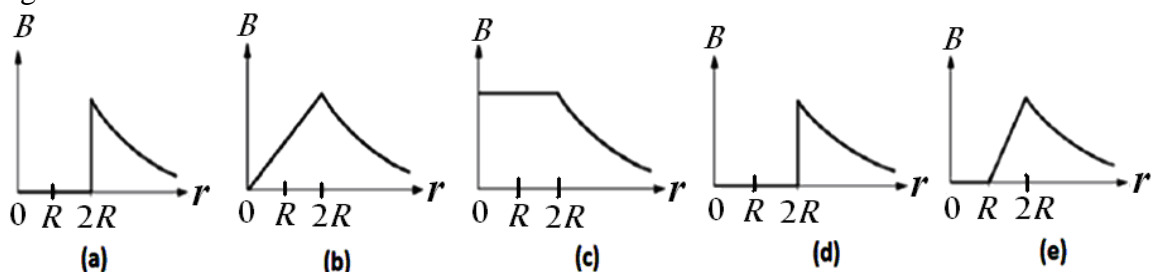

- A) e
- B) a
- C) b
- D) c
- E) d

Q23.

An infinitely long, straight wire is bent, as shown in **FIGURE 10**. The circular portion has a radius of 10.0 cm and its center is a distance r from the straight part. Find the value of r such that the magnetic field at the center of the circular portion is zero.

Fig#

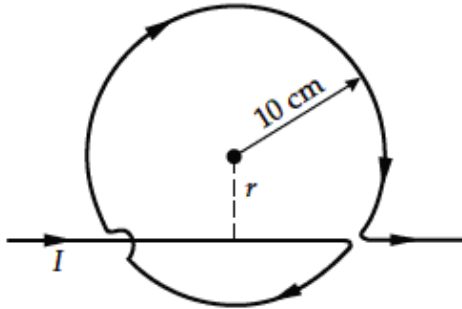

- A) 3.18 cm
- B) 5.22 cm
- C) 1.25 cm
- D) 2.43 cm
- E) 7.08 cm

Q24.

Three long wires **1**, **2** and **3**, are parallel to z -axis and carry currents of equal magnitudes but in different directions, as shown in **FIGURE 11**. The wires form an equilateral triangle. Wire 1 has a linear mass density $0.150 \mu\text{g/m}$. For what value of current is the net magnetic force on wire 1 balanced by its weight.

Fig#

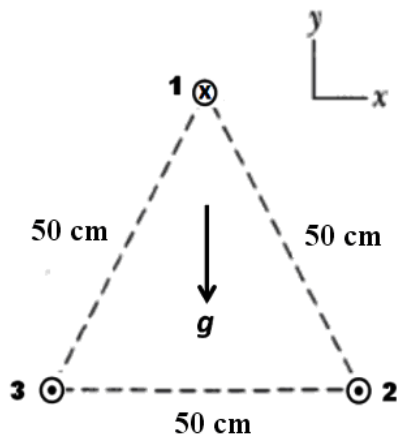

- A) 1.46 A
- B) 0.11 A
- C) 2.89 A
- D) 3.43 A
- E) 0.47 A

Q25.

The magnetic dipole moment of the Earth is $8.0 \times 10^{22} \text{ A}\cdot\text{m}^2$. The source of the earth magnetic dipole moment is due to the circulation of ions in the earth interior region. Assume that the ions move in a circular loop of radius 2500 km, what 'current' should the ions produce to obtain the earth magnetic dipole moment?

- A) $4.1 \times 10^9 \text{ A}$
- B) $3.5 \times 10^9 \text{ A}$
- C) $1.1 \times 10^9 \text{ A}$
- D) $8.2 \times 10^9 \text{ A}$
- E) $7.7 \times 10^9 \text{ A}$

Q26.

A 1.00 m long solenoid has a diameter of 10.0 cm and carries a current of 35.0 A. If the magnetic field inside the solenoid is $100 \times 10^{-3} \text{ T}$, what is the total length of wire of the solenoid?

- A) 714 m
- B) 523 m
- C) 222 m
- D) 855 m
- E) 934 m

Q27.

Which of the following will induce a current in a loop of wire in a uniform magnetic field?

- A) Decreasing the strength of the magnetic field
- B) Rotating the loop about its central axis when it is parallel to the magnetic field.
- C) Moving the loop within the magnetic field parallel to the magnetic field direction.
- D) Moving the loop within the magnetic field perpendicular to the magnetic field direction
- E) None of the others

Q28.

A $10.0 \text{ cm} \times 10.0 \text{ cm}$ square is bent at a 90.0° angle. A uniform 0.050 T -magnetic field points downward at a 45.0° angle, as shown in the **FIGURE 12**. What is the magnetic flux through the bent square?

Fig#

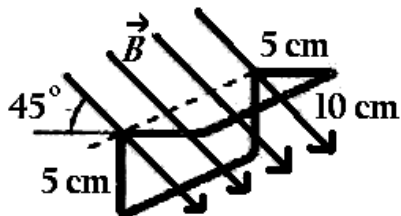

- A) $3.54 \times 10^{-4} \text{ Wb}$
- B) $1.14 \times 10^{-4} \text{ Wb}$
- C) $2.22 \times 10^{-3} \text{ Wb}$
- D) $5.19 \times 10^{-3} \text{ Wb}$
- E) $1.02 \times 10^{-5} \text{ Wb}$

Q29.

A coil formed by wrapping 50.0 turns of wire in the shape of a square is positioned in a magnetic field so that the normal to the plane of the coil makes an angle of 30.0° with the direction of the field. When the magnetic field is increased uniformly from $200 \mu\text{T}$ to $600 \mu\text{T}$ in 0.400 s , an emf of 80.0 mV is induced in the coil. What is the total length of the wire in the coil?

- A) 272 m
- B) 155 m
- C) 102 m
- D) 312 m
- E) 477 m

Q30.

A metal bar of length 80 cm moves with a constant speed $\mathbf{v} = 65 \text{ cm/s}$ on two frictionless rails in a region containing a uniform magnetic field $\mathbf{B} = 0.50 \text{ T}$, as shown in **FIGURE 13**. If the resistance $R = 0.5 \Omega$, what are the magnitude and direction of the magnetic force on the bar?

Fig#

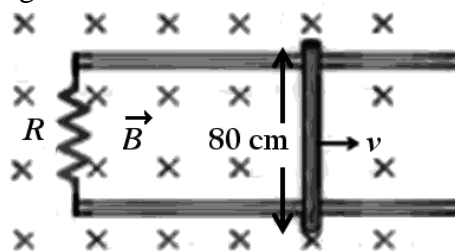

- A) 0.21 N to the left
- B) 0.21 N to the right
- C) 0.42 N to the right
- D) 0.42 N to the left
- E) 0.55 N to the right