

Q1.

A transverse wave on a string is described by the equation:

$$y = (2.0 \text{ m}) \sin [(4.0 \text{ m}^{-1}) x + (60 \text{ s}^{-1}) t]$$

The tension in the string is 0.072 N. The linear mass density of the string is

- A) $3.2 \times 10^{-4} \text{ kg/m}$
- B) $2.2 \times 10^{-4} \text{ kg/m}$
- C) $5.4 \times 10^{-4} \text{ kg/m}$
- D) $7.8 \times 10^{-4} \text{ kg/m}$
- E) $1.2 \times 10^{-4} \text{ kg/m}$

Q2.

A certain sound source is increased in sound level by 40 dB. By what factor is the sound intensity increased?

- A) 10^4
- B) 10^2
- C) 54
- D) 220
- E) 3.0

Q3.

One mole of an ideal gas is first compressed isothermally at 300.0 K to one half of its original volume. Next, 400.0 J of heat is transferred to it at constant volume. The total work done on the gas and the total change in its internal energy are, respectively,

- A) 1728 J; 400.0 J
- B) 2016 J; 582.0 J
- C) 2416 J; 2416 J
- D) 2516 J; 600.0 J
- E) 898.0 J; 400.0 J

Q4.

A 1.00-kg piece of iron, initially at 800 °C, is dropped into 0.20 kg of water initially at 20 °C. How much water boils away? The specific heat of iron is 449 J/kg.K.

- A) 0.11 kg
- B) 0.20 kg
- C) 0.042 kg
- D) 0.32 kg
- E) 0.17 kg

Q5.

A Carnot heat engine operates between reservoirs at 300 K and 550 K. During each cycle, it absorbs 1000 J from the hot reservoir. What is the net change in the entropy of the engine for a complete cycle?

- A) Zero
- B) +1.82 J/K
- C) -1.82 J/K
- D) -352 J/K
- E) +352 J/K

Q6.

At what separation would the force between a stationary proton and a stationary electron be 1.00 N?

- A) 1.52×10^{-14} m
- B) 1.08×10^{-14} m
- C) 2.15×10^{-19} m
- D) 3.21×10^{-12} m
- E) 3.81 m

Q7.

Three particles, each with positive charge Q , form an equilateral triangle, with each side of length d . What is the magnitude of the electric field produced by the particles at the midpoint of any side?

- A) $\frac{Q}{3\pi\epsilon_0 d^2}$
- B) $\frac{Q}{4\pi\epsilon_0 d^2}$
- C) $\frac{Q}{\pi\epsilon_0 d^2}$
- D) $\frac{3Q}{4\pi\epsilon_0 d^2}$
- E) $\frac{3Q}{\pi\epsilon_0 d^2}$

Q8.

Two large metal plates each of area 2.0 m^2 face each other, 1.0 mm apart with equal charge magnitudes $|q|$ but opposite signs. The field magnitude E between them (neglect fringing) is 110 N/C . Find $|q|$.

- A) 1.95 nC
- B) 0.486 nC
- C) 3.90 nC
- D) 0.975 nC
- E) Zero

Q9.

An electric potential function has the following form $V(x,y) = 2x^3y - 3xy^2z$, where V is in volts, x , y , and z are in meters. What is the electric field (in V/m) at the point $(1.0, 1.0, 0) \text{ m}$?

- A) $-6.0\hat{i} - 2.0\hat{j} + 3.0\hat{k}$
- B) $+6.0\hat{i} + 2.0\hat{j}$
- C) $-4.0\hat{j} + 3.0\hat{k}$
- D) $+2.0\hat{j} - 3.0\hat{k}$
- E) $25\hat{i} - 12\hat{j} - 1\hat{k}$

Q10.

Figure 1 shows three sets of cross sections of equipotential surfaces: all three cover the same size region of space. Rank the arrangement according to the magnitude of the electric field, greatest first.

Fig#

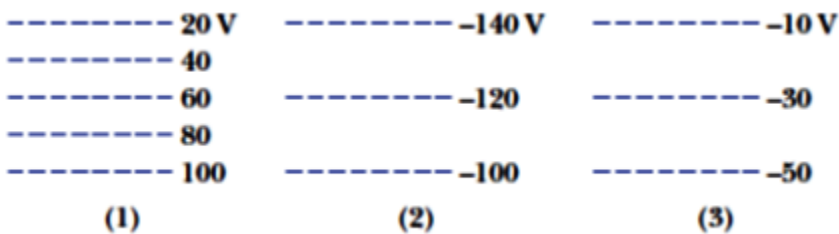

- A) (1); (2) and (3) tie
- B) (1); (2); (3)
- C) (3); (1); (2)
- D) (2) and (3) tie; (1)
- E) all tie

Q11.

Figure 2a shows plots of charge versus potential difference for two capacitors. **Figure 2b** shows a circuit with the two capacitors connected to a 10 V battery. Calculate the total energy stored in the capacitors in **Figure 2b**.

Fig#

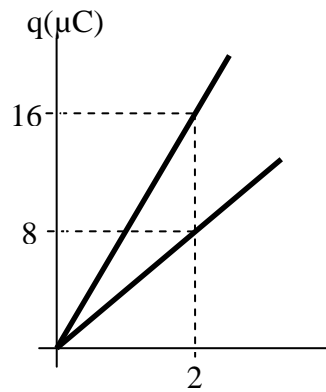

Figure 2a

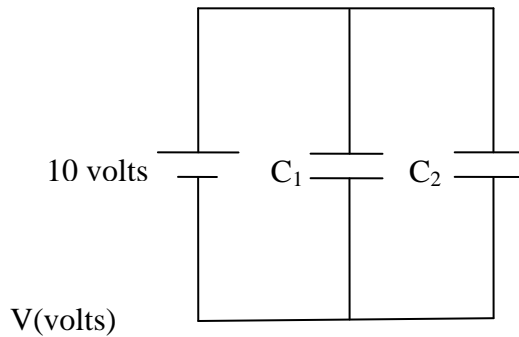

Figure 2b

- A) 600 μJ
- B) 582 μJ
- C) 890 μJ
- D) 25 μJ
- E) 1200 μJ

Q12.

Three wires are made from the same material with the same length but different cross sectional areas. The cross sectional area of wire #1 is A , that of #2 is $2A$, and that of #3 is $3A$. If the same potential difference is applied across the two ends of each wire, rank the wires according to the current density through each, greatest first.

- A) All tie
 B) #1, #2, #3
 C) #3, #2, #1
 D) #3, #1, #2
 E) #2, #1, #3

Q13.

In the circuit shown in **Figure 3**, $I_1 = 6.0 \text{ A}$ and $I_3 = -1.0 \text{ A}$. What is the equivalent resistance of the network of the five resistors shown in the figure?

Fig#

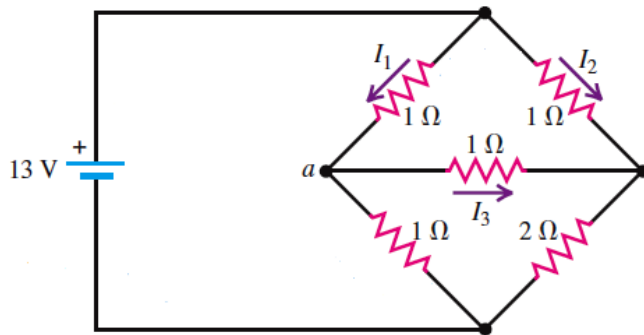

- A) $1.2 \ \Omega$
 B) $0.55 \ \Omega$
 C) $6.0 \ \Omega$
 D) $4.5 \ \Omega$
 E) $0.22 \ \Omega$

Q14.

An initially charged capacitor is discharged through a resistor. In terms of the time constant (τ), how long does it take to lose one-half of the energy that was initially stored in the capacitor?

- A) $(\tau \cdot \ln 2)/2$
 B) $(2\tau)/\ln 2$
 C) $\tau/2$
 D) $\tau/(\ln 2)$
 E) $\tau \cdot \ln 2$

Q15.

An ohmmeter connected across a and b in **Figure 4** reads $2.0 \ \Omega$. What is the resistance of X ?

Fig#

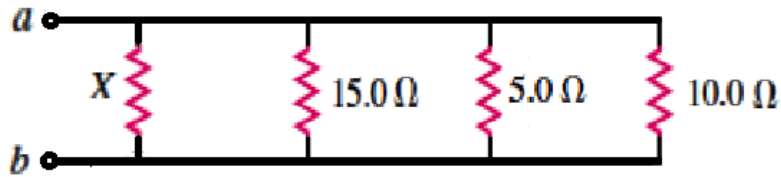

- A) 7.5Ω
- B) 0.37Ω
- C) 2.7Ω
- D) 0.13Ω
- E) 3.7Ω

Q16.

Figure 5 shows a circuit with ideal batteries. If $I = 0.60 \text{ A}$, what is the potential difference $V_a - V_b$?

Fig#

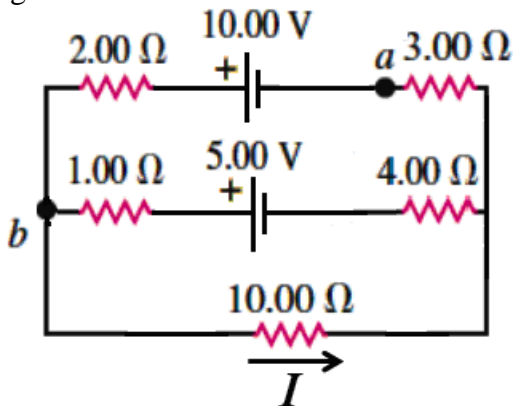

- A) -8.4 V
- B) $+8.4 \text{ V}$
- C) -5.6 V
- D) $+5.6 \text{ V}$
- E) -4.0 V

Q17.

Three identical resistors, each of resistance 5.0Ω , are connected in series to a 9.0 V battery. The power supplied by the battery is

- A) 5.4 W
- B) 4.9 W
- C) 1.8 W
- D) 3.7 W
- E) 6.7 W

Q18.

A charged particle is injected into a uniform magnetic field with its velocity perpendicular to the field. If the speed of the particle is doubled, how is the period of the motion affected?

- A) The period is unaffected.
- B) The period will increase by a factor of 2.
- C) The period will increase by a factor of 4.
- D) The period will decrease by a factor of 2.
- E) The period will decrease by a factor of 4.

Q19.

A particle of mass 0.195 g carries a charge of -25.0 nC. The particle is given an initial horizontal velocity (as shown in **Figure 6**) that has a magnitude of 4.00×10^4 m/s. What are the magnitude and direction of the minimum magnetic field that will keep the particle moving in a straight horizontal line?

Fig#



- A) 1.91 T, out of the page
- B) 1.91 T, into the page
- C) 3.06 T, into the page
- D) 3.53 T, into the page
- E) 3.53 T, out of the page

Q20.

A rectangular loop of wire with an area of 770 cm² carries a current of 1.40 A, as shown in **Figure 7**. It is placed in a uniform magnetic field of magnitude 1.50 T, directed to the right. The torque (in units of N.m) on the loop is

Fig#

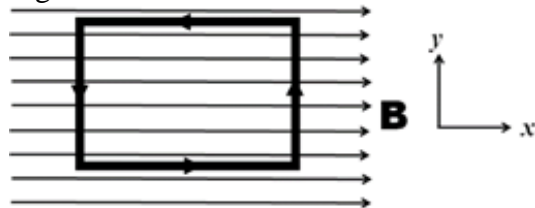

- A) $+0.162 \hat{j}$
- B) $+0.108 \hat{k}$
- C) $-0.162 \hat{j}$
- D) $-0.108 \hat{k}$

E) $+ 0.108 \hat{i}$

Q21.

Part of a current-carrying wire is in a uniform magnetic field of magnitude 0.666 T, as shown in **Figure 8**. If the current is 6.00 A, what is the net force that the magnetic field exerts on the wire?

Fig#

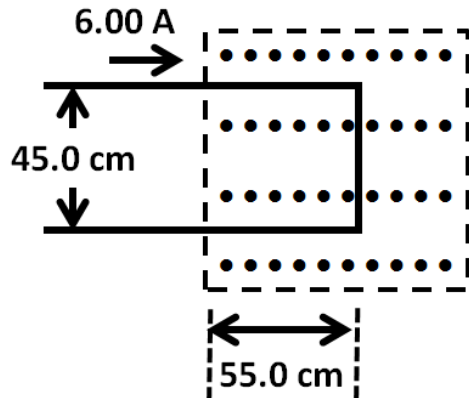

- A) 1.80 N, to the left
- B) 1.80 N, to the right
- C) 0
- D) 6.19 N, to the left
- E) 6.19 N, to the right

Q22.

A coil with a magnetic moment of $1.5 \text{ A}\cdot\text{m}^2$ is oriented initially with its magnetic moment antiparallel to a uniform magnetic field of magnitude 0.85 T. What is the change in the potential energy of the coil when it is rotated 180° so that its magnetic moment is parallel to the field?

- A) $- 2.6 \text{ J}$
- B) $+ 2.6 \text{ J}$
- C) Zero
- D) $- 1.3 \text{ J}$
- E) $+ 1.3 \text{ J}$

Q23.

Four very long, current-carrying wires in the same plane intersect to form a square 40 cm on each side, as shown in **Figure 9**. Find the magnitude and direction of the current I so that the magnetic field at the center of the square is zero. The wires are insulated from each other.

Fig#

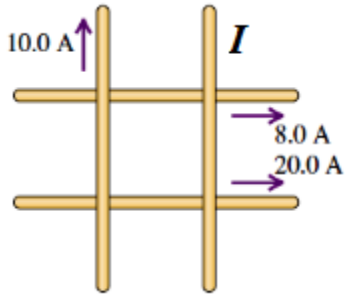

- A) 2.0 A, downward
 B) 2.0 A, upward
 C) 4.0 A, downward
 D) 4.0 A, upward
 E) 6.0 A, downward

Q24.

Three parallel long wires are placed as shown in **Figure 10**. The top and bottom wires carry the same current (2.0 A) in the same direction. What should be the direction and magnitude of the current in the middle wire so that the net magnetic force per unit length on the top wire is zero?

Fig#

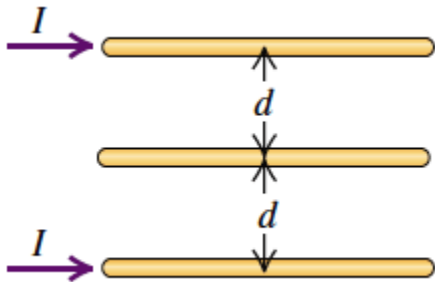

- A) 1.0 A, to the left
 B) 1.0 A, to the right
 C) 4.0 A, to the left
 D) 4.0 A, to the right
 E) 0.50 A, to the left

Q25.

In **Figure 11**, current $I = 1.5$ A is set up in a loop having four radial lengths and four quarter circles, with $r = 5.0$ cm and $R = 2r$. What is the magnitude of the magnetic field at the common center point P ?

Fig#

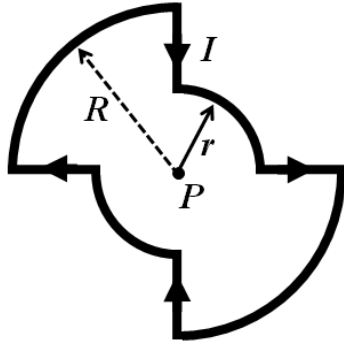

- A) $14 \mu\text{T}$
- B) $43 \mu\text{T}$
- C) $11 \mu\text{T}$
- D) $45 \mu\text{T}$
- E) $91 \mu\text{T}$

Q26.

A solenoid, of length 0.25 m and diameter 15 cm, has 650 turns and carries a current of 0.85 A. What is the magnitude of the magnetic field at the center of the solenoid?

- A) 2.8 mT
- B) 6.9 mT
- C) 4.3 mT
- D) 9.8 mT
- E) 6.4 mT

Q27.

A solid conductor of radius a is surrounded by a conducting tube of inner radius b and outer radius c , as shown in cross section in **Figure 12**. The conductor and the tube carry equal but opposite currents, and the region between them is filled with an insulator. Let r be the distance from the center of the solid conductor. At what value of r will the magnetic field have its maximum value?

Fig#

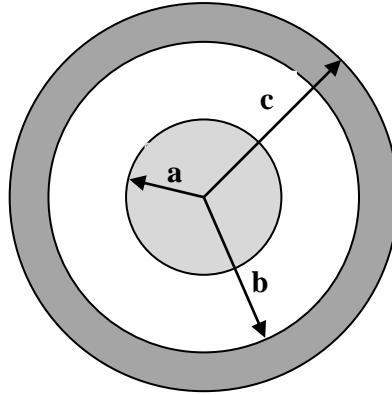

- A) $r = a$
- B) $r < a$
- C) $a < r < b$
- D) $r = b$
- E) $r = c$

Q28.

If the circular conductor in **Figure 13** undergoes thermal expansion while it is in a uniform magnetic field, a current is induced counterclockwise around it. What is the direction of the magnetic field?

Fig#

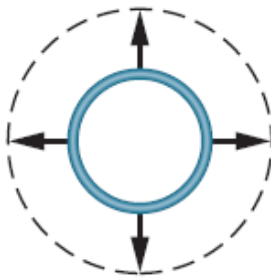

- A) into the page
- B) out of the page
- C) pointing to the right side of the page
- D) pointing to the left side of the page
- E) pointing to the top of the page

Q29.

A magnetic field given by $B(t) = 0.2t - 0.5t^2$ (T) is directed perpendicular to the plane of a circular coil containing 25 turns of radius 1.8 cm and total resistance of 1.5Ω . Find the induced current at $t = 3$ s.

- A) 47.5 mA
- B) 52.1 mA
- C) 35.2 mA
- D) 12.8 mA
- E) 68.1 mA

Q30.

A loop of area 10.00 cm^2 and resistance $5.2 \mu\Omega$ is perpendicular to a uniform magnetic field of magnitude $17.0 \mu\text{T}$. The field magnitude drops uniformly to zero in 2.96 ms . How much thermal energy is produced in the loop by the change in the field?

- A) 18.8 nJ
 - B) 12.5 nJ
 - C) 25.1 nJ
 - D) 88.4 nJ
 - E) 21.4 nJ
-