

Q1.

Fig 1 shows two resistors  $3.0\ \Omega$  and  $1.5\ \Omega$  connected in parallel and the combination is connected in series to a  $4.0\ \Omega$  resistor and a  $10\ \text{V}$  emf device. The potential difference  $V_a - V_b$  is:

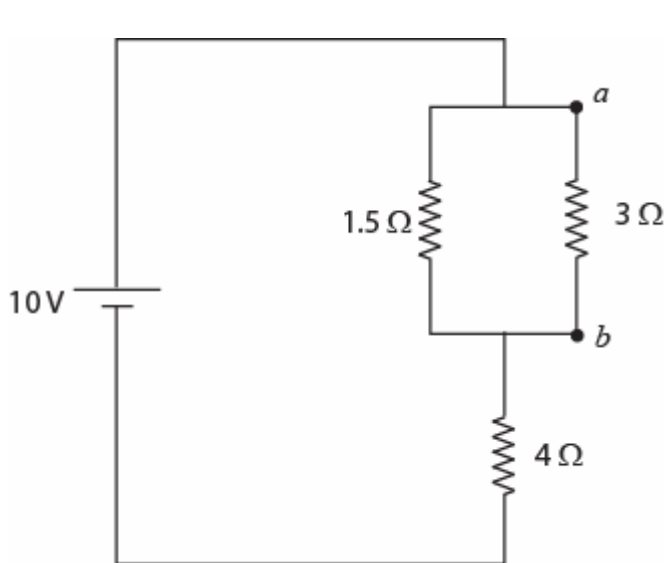

- A) 2.0 V
- B) 6.0 V
- C) 8.0 V
- D) 10 V
- E) 12 V

Q2.

A certain capacitor,  $C$ , in series with a resistor,  $R$ , is being charged. At the end of  $10\ \text{ms}$  its charge is half the maximum value. The time constant of the RC circuit is:

- A) 14 ms
- B) 2.3 ms
- C) 6.9 ms
- D) 10 ms
- E) 43 ms

Q3.

When switch  $S$  is open, the ammeter in the circuit shown in Fig 2 reads  $2.0\ \text{A}$ . When  $S$  is closed, the ammeter reading:

Fig#

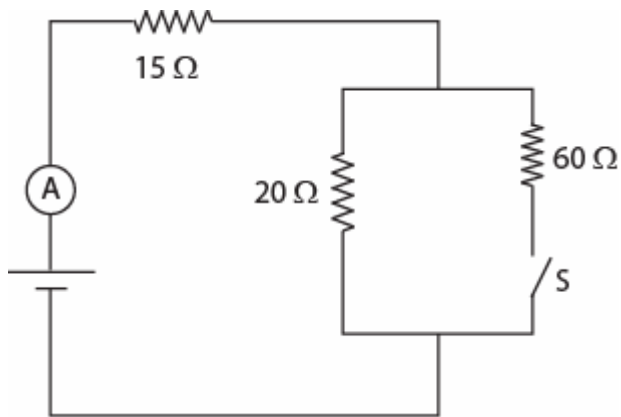

- A) increases  
 B) remains the same  
 C) decreases  
 D) doubles  
 E) gives zero current

Q4.

In Fig 3, what is the potential difference  $V_a - V_b$ ?

Fig#

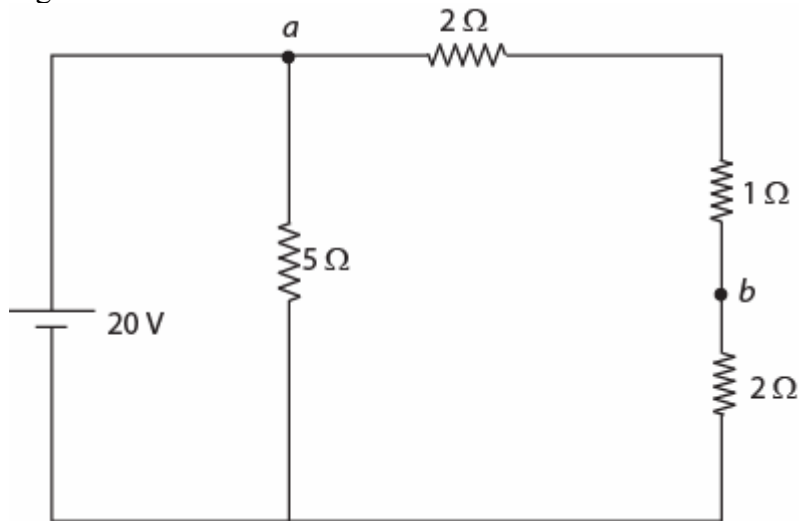

- A) 12 V  
 B) 8 V  
 C) 24 V  
 D) 18 V  
 E) 2 V

Q5.

A particle (mass = 6.0 mg) moves with a speed of 4.0 km/s in a direction that makes an angle of  $37^\circ$  above the positive x axis in the x-y plane. At the instant it enters a magnetic field of  $(5.0 \times 10^{-3} \hat{i})$  T, it experiences an acceleration of  $(8.0 \hat{k})$  m/s<sup>2</sup>. What is the charge of the particle?

- A)  $-4.0 \mu\text{C}$
- B)  $+4.0 \mu\text{C}$
- C)  $-5.0 \mu\text{C}$
- D)  $+5.0 \mu\text{C}$
- E)  $-6.0 \mu\text{C}$

Q6.

A square loop of side 0.20 m consists of 50 closely wrapped turns, each carrying a current of 0.50 A. As shown in the Fig 4, the loop is oriented in a uniform magnetic field of 0.40 T directed in the positive y direction. What is the magnitude of the torque on the loop?

Fig#

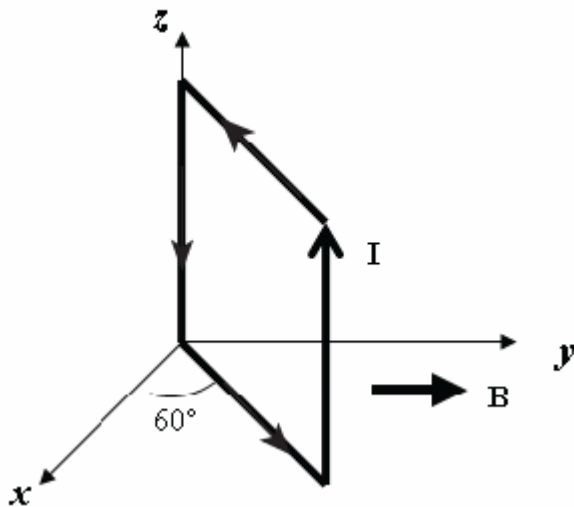

- A) 0.35 N.m
- B) 0.52 N.m
- C) 0.41 N.m
- D) 0.20 N.m
- E) 0.11 N.m

Q7.

When does a magnetic field exert a force on a charged particle?

- A) if the particle is moving perpendicular to the magnetic field lines
- B) always
- C) never

- D) if the particle is moving along the magnetic field lines  
 E) if the particle is at rest

Q8.

Fig 5 shows a loop of wire carrying a current of 2.0 A. The loop has the shape of a right angled triangle with two equal sides, each 20 cm long. A 1.5 T uniform magnetic field is parallel to the hypotenuse. The resultant magnetic force on the two equal sides has a magnitude of:

Fig#

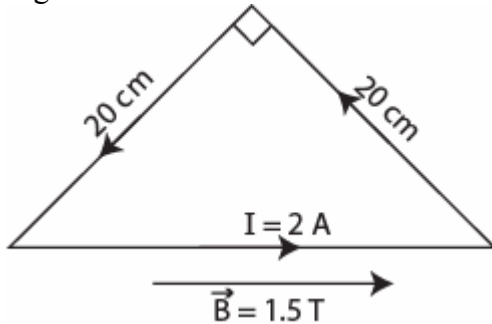

- A) 0 N  
 B) 0.21 N  
 C) 0.30 N  
 D) 0.41 N  
 E) 0.51 N

Q9.

An ion with a charge of  $+4.8 \times 10^{-19} \text{ C}$  is in a region where a uniform electric field of  $6.0 \times 10^4 \text{ V/m}$  is perpendicular to a uniform magnetic field of 1.8 T. If its acceleration is zero then its speed must be:

- A)  $3.3 \times 10^4 \text{ m/s}$   
 B)  $1.6 \times 10^4 \text{ m/s}$   
 C)  $4.0 \times 10^4 \text{ m/s}$   
 D)  $1.0 \times 10^4 \text{ m/s}$   
 E)  $9.8 \times 10^4 \text{ m/s}$

Sec# Magnetic Fields - Motion of a Charged Particle in a Magnetic Field  
 Grade# 50

Q10.

Two long straight wires penetrate the plane of the paper at two vertices of an equilateral triangle as shown in Fig 6. They each carry 2.0 A, out of the page. The magnetic field at the third vertex (P) has magnitude (in T):

Fig#

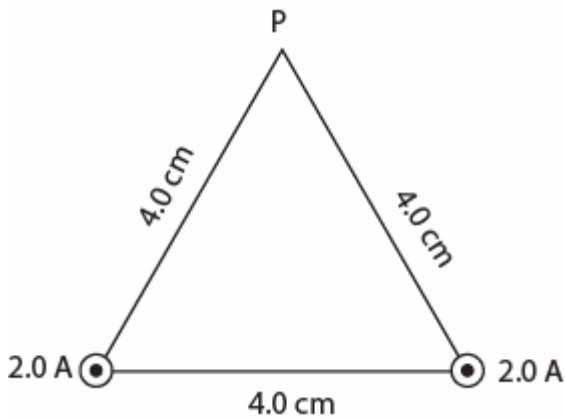

- A)  $1.7 \times 10^{-5}$   
 B)  $1.0 \times 10^{-5}$   
 C)  $2.0 \times 10^{-5}$   
 D)  $5.0 \times 10^{-6}$   
 E)  $8.7 \times 10^{-6}$

Q11.

Four long straight wires carrying equal currents out of the page, are placed at the corners of a square as shown in the Fig 7. The net magnetic force on wire P is:

Fig#

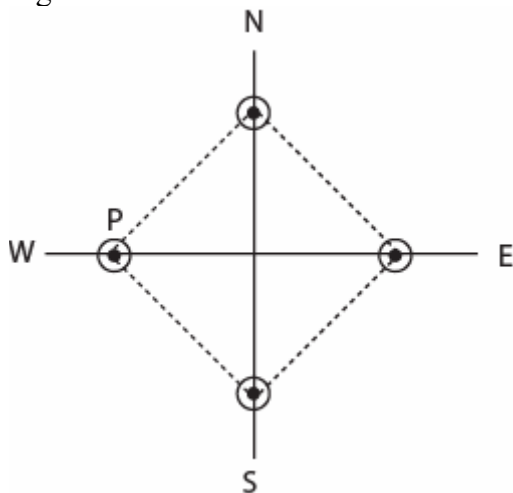

- A) East  
 B) North  
 C) South  
 D) West  
 E) South west

Q12.

A long, coaxial cable, shown in cross-section in Fig 8, is made of two conductors that share a common central axis, labeled C. The current in the *inner* conductor is 2.0 A directed *into the*

page and that in the *outer* conductor is 2.5 A directed *out of the page*. The distance from point C to B is 0.0030 m. What is the magnitude and direction of the magnetic field at point B?

Fig#

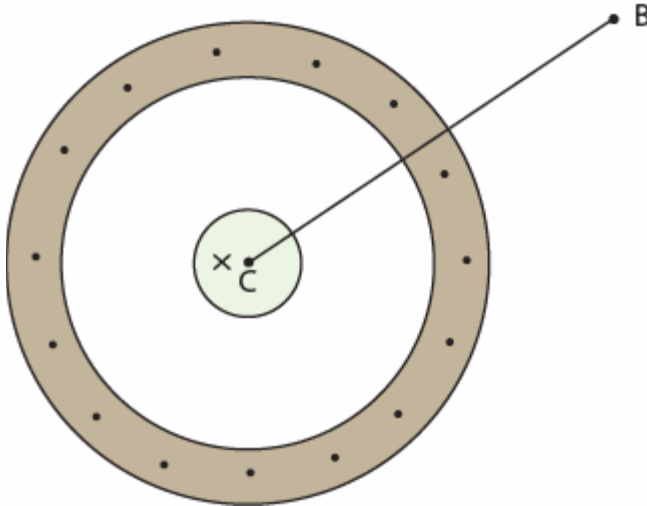

- A)  $3.3 \times 10^{-5}$  T, counterclockwise  
 B)  $6.8 \times 10^{-5}$  T, counterclockwise  
 C)  $3.3 \times 10^{-5}$  T, clockwise  
 D)  $2.7 \times 10^{-4}$  T, clockwise  
 E)  $6.8 \times 10^{-5}$  T, clockwise

Q13.

Solenoid 2 has twice the radius and six times the number of turns per unit length as solenoid 1. Find the ratio of the magnetic field in the interior of solenoid 2 to that in the interior of solenoid 1, if the two solenoids carry the same current.

- A) 6  
 B) 4  
 C) 2  
 D) 1  
 E) 1/3

Q14.

A long straight wire is in the plane of two circular conducting loops. The straight wire carries a constant current  $I$  in the direction shown in Fig 9. The circular loop 1 is moved to the right while the loop 2 is moved to the left with the same speed,  $v$ . The induced current directions in the circular loops 1 and 2 are respectively:

Fig#

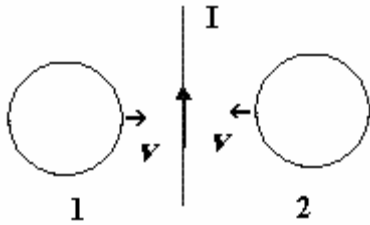

- A) Clockwise , counterclockwise  
 B) Clockwise, clockwise  
 C) Counterclockwise, clockwise  
 D) Counterclockwise, counterclockwise  
 E) No current in both the loops

Q15.

A circuit is pulled to the right at constant speed in a uniform magnetic field with a 16 N force as shown in Fig 10. As the circuit moves, a 6.0 A current flows through the 4.0  $\Omega$  resistor. With what speed does the circuit move?

Fig#

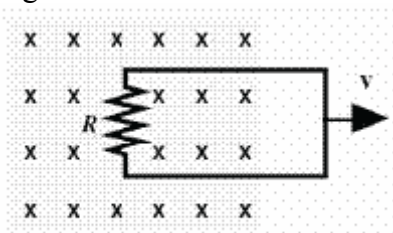

- A) 9.0 m/s  
 B) 3.0 m/s  
 C) 6.4 m/s  
 D) 12 m/s  
 E) 1.5 m/s

Q16.

A 2.0 m long copper wire, with resistance 5.0  $\Omega$ , is shaped into a square loop and placed perpendicular to a uniform magnetic field that is increasing at the constant rate of  $1.0 \times 10^{-2}$  T/s. At what rate is thermal energy generated in the loop?

- A)  $1.3 \times 10^{-6}$  W.  
 B)  $4.5 \times 10^{-6}$  W.  
 C)  $3.2 \times 10^{-6}$  W.  
 D)  $2.1 \times 10^{-4}$  W.  
 E)  $1.1 \times 10^{-7}$  W.

Q17.

A string, clamped at both ends, vibrates in three segments. The string is 90.0 cm long. The wavelength is:

- A) 60.0 cm
- B) 30.0 cm
- C) 90.0 cm
- D) 270 cm
- E) 135 cm

---

Q18.

A source emits sound with a frequency of 500 Hz. The source and the observer are moving in the same direction with the same speed, 50 m/s. If the speed of sound is 340 m/s, the observer hears sound with a frequency of:

- A) 500 Hz
- B) 100 Hz
- C) 1000 Hz
- D) 1500 Hz
- E) 250 Hz

---

Q19.

If the speed of sound is 340 m/s, the length of the shortest closed pipe (one end closed) that resonates at 300 Hz is:

- A) 28 cm
- B) 17 cm
- C) 44 cm
- D) 88 cm
- E) 156 cm

---

Q20.

One mole of an ideal gas expands reversibly and isothermally at temperature  $T$  until its volume is doubled. The change in entropy of this gas during this process is:

- A)  $R \ln 2$
- B)  $(\ln 2)/T$
- C) 0
- D)  $RT \ln 2$
- E)  $2R$

---

Q21.



Both the pressure and volume of an ideal gas of diatomic molecules are doubled. The ratio of the new internal energy to the old internal energy is (the internal energy at 0 K is zero):

- A) 4
- B) 1 / 2
- C) 1
- D) 2
- E) 1 / 4

---

Q22.

In a thermodynamic process, the internal energy of a system in a container with adiabatic walls decreases by 800 J. Which of the following statements is correct?

- A) The system performed 800 J of work on its surroundings.
- B) The system gained 800 J by heat transfer from its surroundings.
- C) The system lost 800 J by heat transfer to its surroundings.
- D) The surrounding performed 800 J of work on the system.
- E) The 800 J of work done by the system was equal to the 800 J of heat transferred to the system from its surroundings.

---

Q23.

An electrical insulator is a material

- A) through which electrons do not flow easily
- B) containing no electrons
- C) that has more electrons than protons on its surface
- D) through which electrons flow easily
- E) has very low resistance

---

Q24.

Consider two negative point charges  $q_1$  at (10, 0) cm and  $q_2$  at (0, 20) cm. Find the ratio of the magnitudes of these two point charges  $|q_1/q_2|$  so that the electric field at the origin makes an angle =  $45^\circ$  with +x axis.

- A) 1/4
- B) 1
- C) 1/2
- D) 2
- E) 4

---

Q25.

Charge is distributed uniformly on the surface of a large flat plate. The electric field 2.0 cm above the center of the plate is 20 N/C. The electric field 4.0 cm above the center of the plate is:

- A) 20 N/C
- B) 80 N/C
- C) 40 N/C
- D) 10 N/C
- E) 0 N/C

---

Q26.

The work required by an external agent to carry a particle with a charge of 6.0 C from a 5.0 V equipotential surface to a 6.0 V equipotential surface and back again to the 5.0 V surface is:

- A) 0 J
- B)  $2.2 \times 10^{-6}$  J
- C)  $3.2 \times 10^{-6}$  J
- D)  $2.2 \times 10^{-5}$  J
- E)  $3.2 \times 10^{-5}$  J

---

Q27.

The electric potential at a point A in an electric field is 15 V smaller than that at point B. A charge  $q = -2.0$  C is released from rest at point A. What is its kinetic energy at point B?

- A) +30 J.
- B) -30 J.
- C) +25 J.
- D) -15 J.
- E) +15 J.

---

Q28.

A 2  $\mu$ F and a 1  $\mu$ F capacitors are connected in parallel and a potential difference is applied across the combination. The 2  $\mu$ F capacitor has:

- A) twice the charge of the 1  $\mu$ F capacitor
- B) half the charge of the 1  $\mu$ F capacitor
- C) twice the potential difference of the 1  $\mu$ F capacitor
- D) half the potential difference of the 1  $\mu$ F capacitor
- E) none of the other answers

---

Q29.

A parallel plate capacitor whose capacitance is 20 pF is charged by a battery to a potential difference of 10 V between its plates. The battery is now disconnected and a dielectric slab ( $\kappa = 5$ ) is slipped between the plates. What is the potential energy of the capacitor after the slab is inserted?

- A) 200 pJ
- B) 300 pJ
- C) 400 pJ
- D) 100 pJ
- E) 500 pJ

---

Q30.

A current of 0.300 A is passed through a lamp for 2.00 minutes using a 6.00 V power supply. The energy dissipated by this lamp during the 2.00 minutes is:

- A) 216 J
- B) 1.80 J
- C) 125 J
- D) 20.0 J
- E) 36.0 J