

Q1.

**Figure 1** shows four graphs of the  $x$  component of a variable force  $F_x$  (directed along  $x$  axis) versus the position of a particle on which the force acts. Rank the graphs according to the work done by the force on the particle from  $x = 0$  to  $x = x_1$ , from most positive work to most negative work.

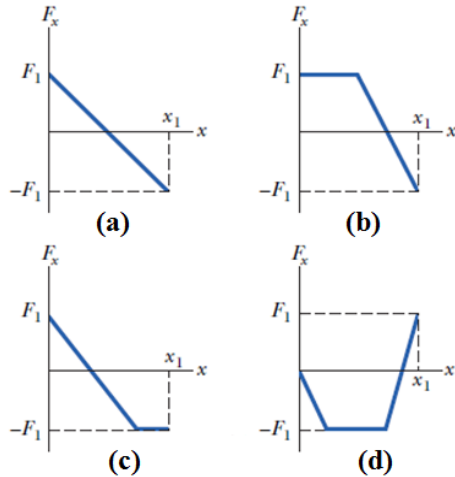

- A) b, a, c, d
- B) b and d tie, a, c
- C) a, b, c, d
- D) d, b, c, a
- E) d, c, b, a

Q2.

A 20 g particle is moving to the left at a speed of 30 m/s. How much total work must be done on the particle to make it move to the right at a speed of 30 m/s?

- A) Zero J
- B) 9.0 J
- C) -9.0 J
- D) 18 J
- E) -18 J

Q3.

A 20 kg child slides 3.5 m down a vertical pole to the house floor, starting from rest. What is the kinetic energy of the child as he reaches the floor if the frictional force on him from the pole is negligible?

- A)  $6.9 \times 10^2$  J
- B)  $4.1 \times 10^2$  J
- C)  $2.5 \times 10^2$  J
- D)  $7.9 \times 10^2$  J
- E)  $8.2 \times 10^2$  J

Q4.

A point object is acted on by a force  $\vec{F} = (4.00 \text{ N})\hat{i} - (2.50 \text{ N})\hat{j} + (9.00 \text{ N})\hat{k}$ . At an instant, the object's velocity has only y component and the instantaneous rate at which the force does work on the object is  $-12.0 \text{ W}$ . Determine the instantaneous speed of the object.

- A) 4.80 m/s
- B) 3.52 m/s
- C) 2.77 m/s
- D) 5.89 m/s
- E) 6.06 m/s

Q5.

A uniform solid sphere of mass  $M = 5.0 \text{ kg}$  and radius  $R = 0.50 \text{ m}$  is free to rotate about a horizontal axis passing through its center. A string is wrapped around the sphere and is attached to an object of mass  $m = 0.10 \text{ kg}$ , as shown in **Figure 2**. Assume that the string does not slip on the sphere. Find the acceleration of mass  $m$ ?

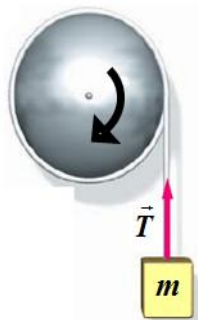

- A)  $0.47 \text{ m/s}^2$
- B)  $0.26 \text{ m/s}^2$
- C)  $0.33 \text{ m/s}^2$
- D)  $0.52 \text{ m/s}^2$
- E)  $0.66 \text{ m/s}^2$

Q6.

A child whose weight is  $267 \text{ N}$  moves down a distance  $d = 6.10 \text{ m}$  along a slide that makes an angle of  $20.0^\circ$  with the horizontal, as shown in **Figure 3**. If coefficient of kinetic friction between slide and child is  $0.100$ , what is change in kinetic energy of the child over the distance "d"?

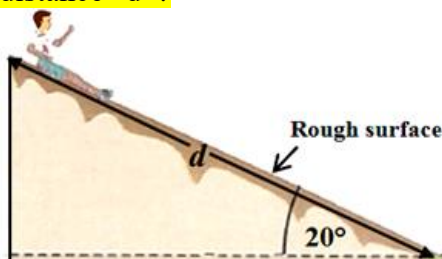

- A) 404 J
- B) 355 J
- C) 222 J
- D) 511 J
- E) 659 J

Q7.

In **Figure 4**, a 3.5 kg block is accelerated over a horizontal frictionless floor from rest by a compressed spring with negligible mass and a spring constant of  $9.7 \times 10^2$  N/m. The block leaves the spring at its relaxed length with a speed of 1.5 m/s. What was the compression distance of the spring?

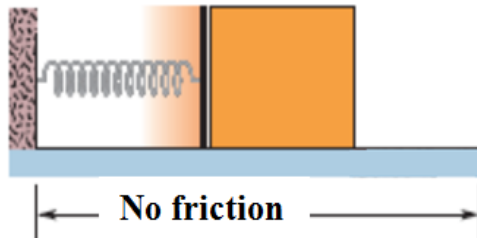

- A) 9.0 cm
- B) 6.7 cm
- C) 3.5 cm
- D) 11 cm
- E) 13 cm

Q8.

A stone attached to end of 3.8 m long string is swinging in a vertical plane. If the string makes a maximum angle of  $39^\circ$  with the vertical, find maximum speed of the swinging stone? (Ignore air resistance)

- A) 4.1 m/s
- B) 2.4 m/s
- C) 1.9 m/s
- D) 5.3 m/s
- E) 6.1 m/s

Q9.

In **Figure 5**, what value of  $F_{max}$  gives an impulse of 60 N.s?

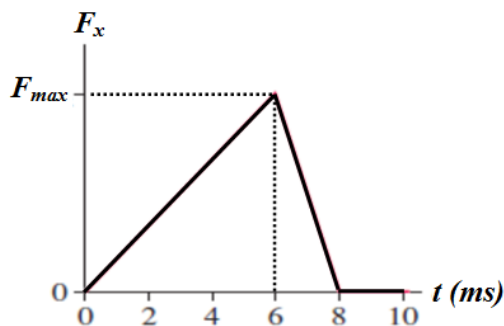

- A)  $15 \times 10^3$  N
- B)  $13 \times 10^3$  N
- C)  $11 \times 10^3$  N
- D)  $21 \times 10^3$  N
- E)  $29 \times 10^3$  N

Q10.

A large 11.5 kg fish is swimming in ocean with velocity  $(0.750 \text{ m/s})\hat{i}$ . Suddenly, it swallows a small 1.25 kg fish which was swimming with velocity  $-(3.60 \text{ m/s})\hat{j}$ . Find the speed of the large fish just after it swallowed the smaller fish. Neglect any effects due to drag of water and air resistance. (Assume ocean water is still)

- A) 0.763 m/s
- B) 0.522 m/s
- C) 0.344 m/s
- D) 0.803 m/s
- E) 0.889 m/s

Q11.

Two skaters, one with mass 60 kg and the other with mass 40 kg, stand on an ice skating frictionless floor holding a 14 m long pole of negligible mass. Starting from the ends of the pole, the skaters pull themselves along the pole until they meet. How far does the 60 kg skater move?

- A) 5.6 m
- B) 2.2 m
- C) 4.5 m
- D) 8.2 m
- E) 9.1 m

Q12.

A body of mass 5.0 kg makes an elastic collision with another body at rest and continues to move in the original direction but with one-fifth of its original speed. What is the mass of the other body?

- A) 3.3 kg
- B) 2.2 kg
- C) 1.7 kg
- D) 5.9 kg
- E) 4.7 kg

Q13.

In the overhead view of **Figure 6**, five forces of the same magnitude act on a merry-go-round; it is a square that can rotate about point  $P$ , at mid-length along one of the edges. Rank the forces according to the magnitude of the torque they produce about point  $P$ , greatest first.

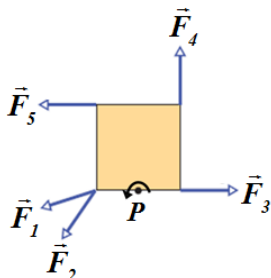

- A)  $F_5, F_4, F_2, F_1$  then  $F_3$
- B)  $F_4, F_2, F_3, F_1$  then  $F_5$
- C)  $F_3, F_1, F_2, F_5$  then  $F_4$
- D)  $F_2, F_4, F_3, F_1$  then  $F_5$
- E)  $F_1, F_2, F_3, F_4$  then  $F_5$

Q14.

A disk rotates at constant angular acceleration, from angular position  $\theta_1 = 12$  rad to angular position  $\theta_2 = 72$  rad in 5.0 s. At  $\theta_2$  its angular velocity  $\omega_2 = 14$  rad/s. What is its angular acceleration?

- A)  $0.80 \text{ rad/s}^2$
- B)  $0.30 \text{ rad/s}^2$
- C)  $0.50 \text{ rad/s}^2$
- D)  $1.5 \text{ rad/s}^2$
- E)  $1.6 \text{ rad/s}^2$

Q15.

Energy is to be stored in a 50 kg uniform rotating disk with 1.0 m radius. The disk is rotating about a vertical axis passing through the center of the disk. If the maximum allowed radial acceleration of a point on its rim is  $5.5 \times 10^2 \text{ m/s}^2$ , what is maximum kinetic energy that can be stored in the rotating disk?

- A)  $6.9 \times 10^3 \text{ J}$
- B)  $5.3 \times 10^3 \text{ J}$
- C)  $2.2 \times 10^3 \text{ J}$
- D)  $7.5 \times 10^3 \text{ J}$
- E)  $8.1 \times 10^3 \text{ J}$

Q16.

**Figure 7** shows three cases involving a block sliding along the rough plane. The block begins with the same speed in all three cases and slides until the kinetic frictional force has stopped it. Rank the situations according to the increase in thermal energy due to the sliding, **greatest first**.

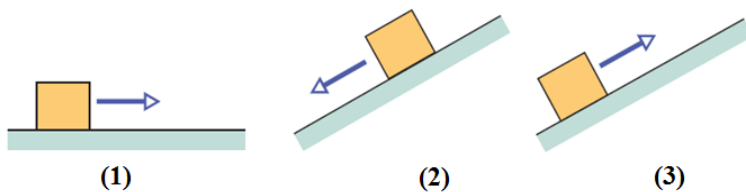

- A) 2, 1, 3
- B) 3, 2, 1
- C) 1, 2, 3
- D) 2, 3, 1
- E) All ties

Q17.

The angular momenta of a particle in four situations are given by equations:

$$(1) \ell = 3t + 4 ; (2) \ell = -6t^2 ; (3) \ell = 2 ; (4) \ell = 4/t$$

In which situation is the net torque on the particle is negative and increasing in magnitude (for  $t > 0$ )

- A) (2)
- B) (1)
- C) (3)
- D) (4) and (1)
- E) (2) and (3)

Q18.

The position vector of a particle of mass 2.0 kg is given as a function of time by  $\vec{r} = 6.0\hat{i} + 5.0t\hat{j}$ . Determine the angular momentum of the particle about the origin as a function of time. Use SI units for time and distance.

- A)  $(60 \text{ kg}\cdot\text{m}^2/\text{s})\hat{k}$
- B)  $-(52 \text{ kg}\cdot\text{m}^2/\text{s})\hat{k}$
- C)  $(41 \text{ kg}\cdot\text{m}^2/\text{s})\hat{k}$
- D)  $-(75 \text{ kg}\cdot\text{m}^2/\text{s})\hat{k}$
- E)  $(82 \text{ kg}\cdot\text{m}^2/\text{s})\hat{k}$

Q19.

A 10 kg solid sphere has a radius of 0.40 m. Starting from rest, how much work is required to get the sphere rolling with an angular speed of 5.0 rad/s on a rough horizontal surface? (Assume the sphere starts from rest and rolls without slipping)

- A) 28 J
- B) 11 J
- C) 21 J
- D) 32 J
- E) 39 J

Q20.

A disk with a rotational inertia  $I = 2.5 \times 10^2 \text{ kg}\cdot\text{m}^2$  and radius  $R = 2.0 \text{ m}$ , rotates about a frictionless, vertical axle like a merry-go-round with an angular speed of  $\omega_0 = 1.7 \text{ rad/s}$ . Facing the axle, a  $25 \text{ kg}$  child jumps onto the disk and sit down at point  $P$  on the edge as shown in the **Figure 8**. What is the new angular speed of the disk?

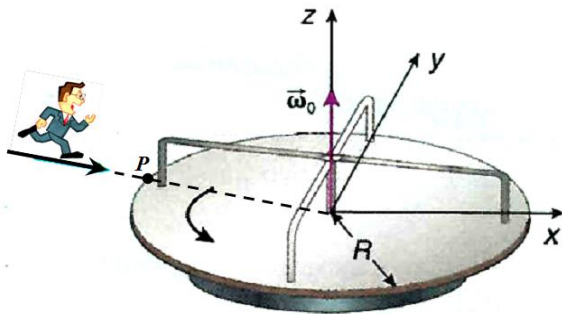

- A) 1.2 rad/s
- B) 1.0 rad/s
- C) 0.90 rad/s
- D) 1.8 rad/s
- E) 2.1 rad/s