

Second Major Exam Questions

Q1. A 10 kg box slides with a constant speed a distance of 5.0 m downward along a rough slope that makes an angle θ with the horizontal (see **Figure 1**). If the work done by the force of gravity is 360 J, the angle θ is:

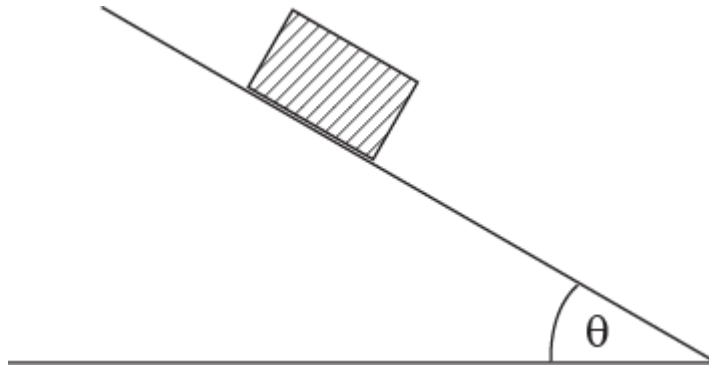

- A) 47°
- B) 37°
- C) 42°
- D) 50°
- E) 75°

Q2. A mechanic pushes a 2.00×10^3 kg car horizontally a distance of 4.00 m from rest to a speed of 4.00 m/s with a constant force. Find the magnitude of the net force acting on the car.

- A) 4.00×10^3 N
- B) 3.00×10^3 N
- C) 4.00×10^4 N
- D) 2.00×10^2 N
- E) 9.00×10^2 N

Q3. A person pulls horizontally a 20 kg box at a constant speed of 3.0 m/s for 10 s. The coefficients of kinetic and static friction between the box and the horizontal floor are 0.30 and 0.60, respectively. What is the work done by the person in pulling the box?

- A) 1.8 kJ
- B) 3.6 kJ
- C) -1.8 kJ
- D) -3.6 kJ
- E) 1.5 kJ

Q4. A machine applies a constant force $\vec{F} = (3.00 \text{ N})\hat{i} + (2.00 \text{ N})\hat{j} + (5.00 \text{ N})\hat{k}$ on a 4.00 kg box. The box is carried from an initial position of $\vec{d}_i = (1.00 \text{ m})\hat{i} + (2.00 \text{ m})\hat{j} - (2.00 \text{ m})\hat{k}$ to a final position of $\vec{d}_f = (6.00 \text{ m})\hat{i} - (3.00 \text{ m})\hat{j} - (2.00 \text{ m})\hat{k}$ in 12.0 s. Find the average power of the machine's force on the box in this time interval of 12.0 s.

- A) 0.417 W
- B) 0.231 W
- C) 3.45 W
- D) 0.864 W
- E) 2.34 W

Q5. A block of mass $m = 12.0 \text{ kg}$ is released from rest on a frictionless incline of angle $\theta = 30.0^\circ$ (see **Figure 2**). Below the block is a spring that can be compressed 2.50 cm by a force of 250 N. The block stops momentarily when it compresses the spring by 4.00 cm. How far does the block move down the incline from its rest position to this stopping point?

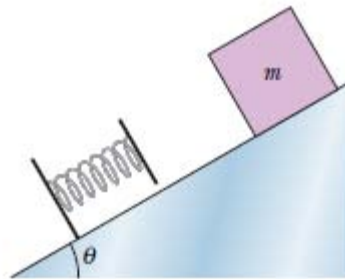

- A) 13.6 cm
- B) 17.0 cm
- C) 8.00 cm
- D) 4.50 cm
- E) 6.50 cm

Q6. A worker does 200 J of work in moving a 20.0 kg box a distance D on a rough horizontal floor. The box starts from rest and its speed after moving the distance D is 4.00 m/s. Find the work done by the force of friction.

- A) -40.0 J
- B) 40.0 J
- C) -200 J
- D) 200 J
- E) 160 J

Q7. In **Figure 3**, a moving block can take three frictionless paths, differing only in elevation (height), to reach the dashed finish line. Rank the paths according to the speed of the block at the finish line, greatest first.

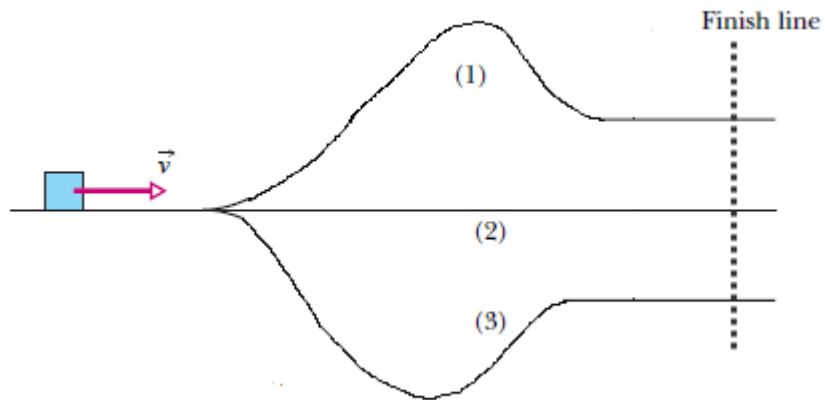

- A) 3,2,1
- B) 1,2,3
- C) 2,3,1
- D) 1,3,2
- E) 2,1,3

Q8. **Figure 4** shows three identical uniform bars, each of mass M and length $2R$, welded to a uniform ring of mass $2M$ and radius R . The bars and the ring are in an xy -plane whose origin O is at the center of the ring. Find the x and y coordinates of the system's center of mass.

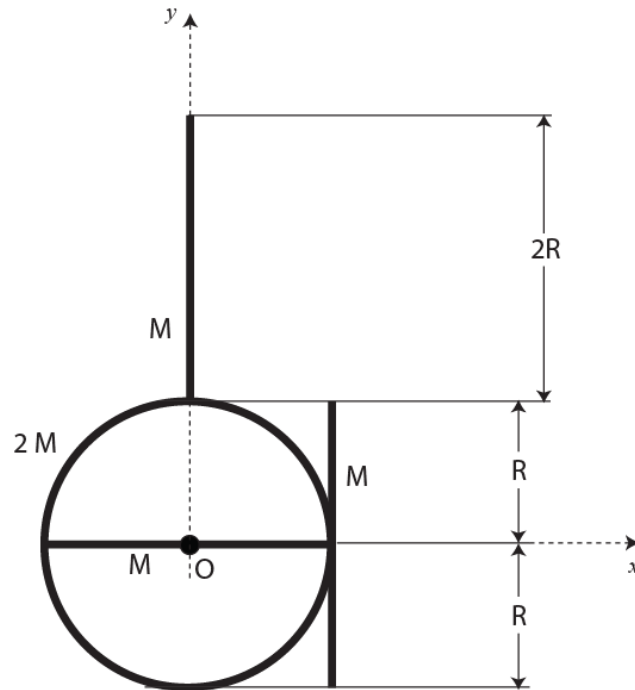

- A) $(0.2 R, 0.4 R)$
- B) $(0.5 R, 0.3 R)$
- C) $(0.5 R, 0.5 R)$
- D) $(0.2 R, 0.5 R)$
- E) $(0.5 R, 0.2 R)$

Q9. Consider a one dimensional collision between two identical balls. One is originally at rest and the other has a velocity of $(4 \text{ m/s}) \hat{i}$. If $3/8$ of the initial kinetic energy is lost during the collision, find the velocities of the balls after the collision.

- A) $(1 \text{ m/s}) \hat{i}$ and $(3 \text{ m/s}) \hat{i}$
- B) $(1 \text{ m/s}) \hat{i}$ and $(5 \text{ m/s}) \hat{i}$
- C) $(2 \text{ m/s}) \hat{i}$ and $(6 \text{ m/s}) \hat{i}$
- D) $(2 \text{ m/s}) \hat{i}$ and $(2 \text{ m/s}) \hat{i}$
- E) 0 and $(4 \text{ m/s}) \hat{i}$

Q10. A ball of mass m , suspended by a light string of length 100 cm is released from a position where the string makes an angle $\theta = 60.0^\circ$ with the vertical (see **Figure 5**). The ball collides with a second identical ball kept at rest on a smooth wedge at the bottom of its swing and the two balls stick together after collision. Determine the maximum vertical height H to which the balls rise after the collision.

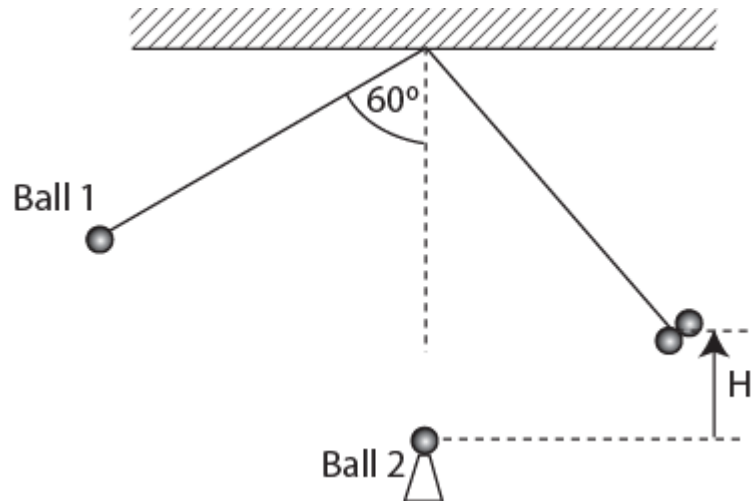

- A) 12.5 cm
- B) 25.0 cm
- C) 50.0 cm
- D) 33.5 cm
- E) 42.5 m

Q11. Ball **A**, moving with velocity $(8 \text{ m/s})\hat{i}$, collides with stationary Ball **B**. Masses of balls **A** and **B** are the same. After the collision, if **B** moves with velocity $(6 \text{ m/s})\hat{j}$, what is the velocity of **A**?

- A) $(8 \text{ m/s})\hat{i} - (6 \text{ m/s})\hat{j}$
- B) $(8 \text{ m/s})\hat{i} + (6 \text{ m/s})\hat{j}$
- C) $-(8 \text{ m/s})\hat{i} - (6 \text{ m/s})\hat{j}$
- D) $-(8 \text{ m/s})\hat{i} + (6 \text{ m/s})\hat{j}$
- E) $-(6 \text{ m/s})\hat{j}$

Q12. A 2.0 kg toy car moves along an x-axis. **Figure 6** shows the net force along the x-axis acting on the car as a function of time. The car begins from rest at $t = 0$. What is the velocity of the car at $t = 9$ s?

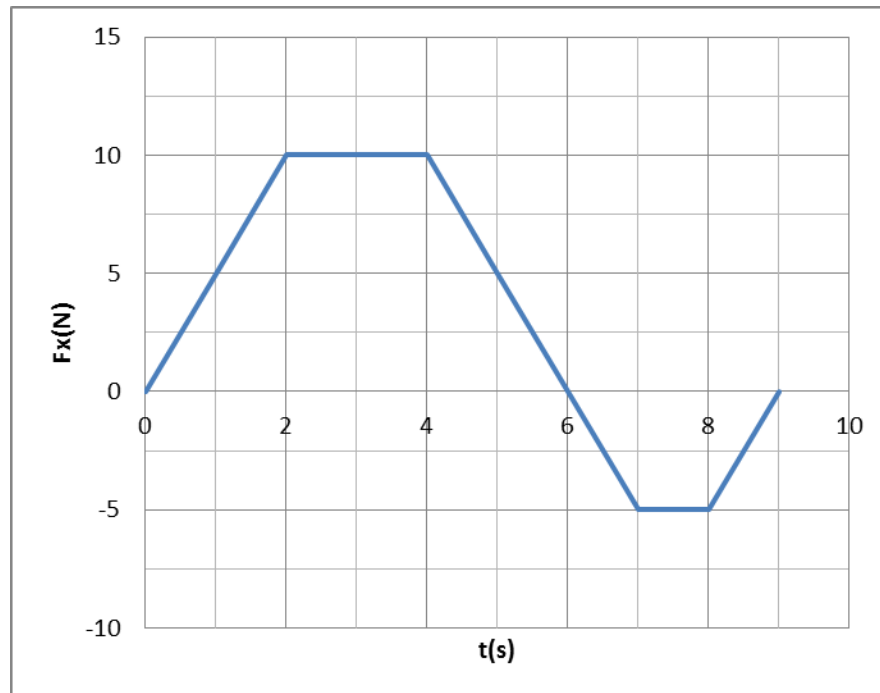

- A) $(15 \text{ m/s})\hat{i}$
- B) $(25 \text{ m/s})\hat{i}$
- C) $-(15 \text{ m/s})\hat{i}$
- D) $-(25 \text{ m/s})\hat{i}$
- E) $(10 \text{ m/s})\hat{i}$

Q13. A disk, initially at rest, is rotated with constant angular acceleration $\alpha = 5.00 \text{ rad/s}^2$ for 8.00 s. The disk is then brought to rest with uniform negative acceleration in 10.0 revolutions. Determine the magnitude of the negative acceleration required.

- A) 12.7 rad/s^2
- B) 15.0 rad/s^2
- C) 10.4 rad/s^2
- D) 1.25 rad/s^2
- E) 16.0 rad/s^2

Q14. **Figure 7** shows a uniform metal plate that had been square before 25% of it was removed. Three lettered points are indicated. Rank them according to the rotational inertia of the plate about a perpendicular axis through them, greatest first.

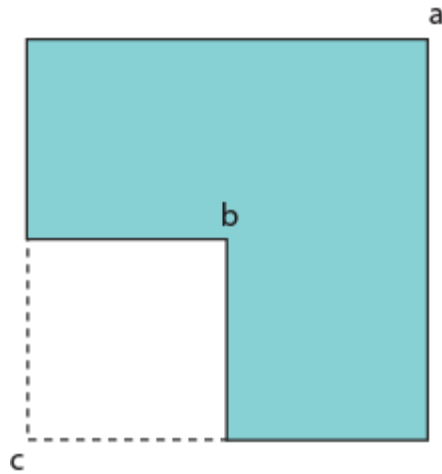

- A) c, a, b
- B) c, a & b tie
- C) a, b & c tie
- D) a, c, b
- E) b, a, c

Q15. A 1.0×10^3 N man is standing 6.0×10^3 km to the East from the center of earth. Find the torque about the center of the earth exerted by the force of gravity on the man. (Assume the Earth is a sphere).

- A) 0
- B) 6.0×10^9 N.m North
- C) 6.0×10^9 N.m South
- D) 6.0×10^9 N.m East
- E) 6.0×10^9 N.m West

Q16. **Figure 8** shows a uniform disk that can rotate around its center. The disk has a radius of 4.00 cm and a mass of 40.0 grams and is initially at rest. Starting at $t = 0$, two forces are to be applied tangentially to the rim as indicated, so that at time $t = 2.50$ s the disk has angular velocity of 250 rad/s clockwise. Force F_1 has a magnitude of 0.100 N. What is the magnitude of F_2 ?

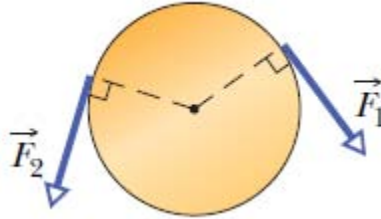

- A) 2.00×10^{-2} N
- B) 6.00×10^{-2} N
- C) 1.50 N
- D) 1.06×10^{-1} N
- E) 4.20×10^{-1} N

Q17. A frictionless pulley has the shape of a uniform solid disk of mass 2.50 kg and radius 20.0 cm. A 1.50 kg stone is attached to a massless wire that is wrapped around the rim of the pulley (**Figure 9**), and the system is released from rest. How far must the stone fall so that the pulley has 4.50 J of kinetic energy?

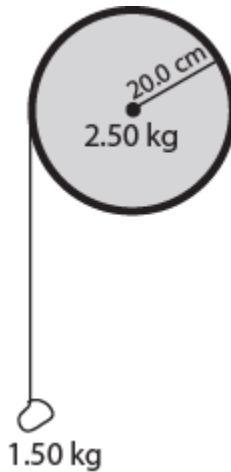

- A) 0.673 m
- B) 0.543 m
- C) 0.876 m
- D) 0.954 m
- E) 1.03 m

Q18. A student releases from rest a solid sphere (object P), a thin-walled hollow sphere (object Q), a solid cylinder (object R), and a thin-walled hollow cylinder (object S) from the same height at the top of an inclined plane (see **Figure 10**). Which one of these objects will reach the bottom of the incline first?

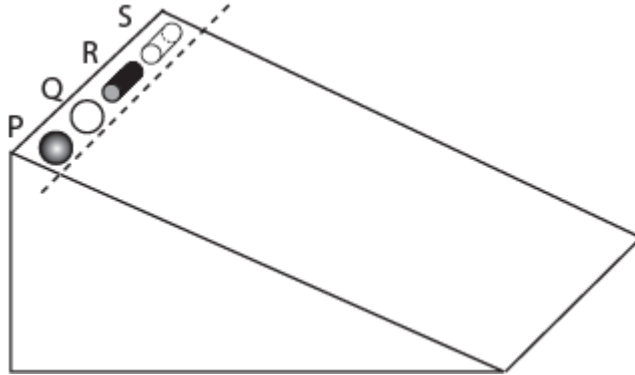

- A) P
- B) Q
- C) R
- D) S
- E) They all take the same time

Q19. **Figure 11** shows three particles of the same mass and the same constant speed moving as indicated by the velocity vectors. Points a, b, c, and d form a square. Rank the **magnitudes** of the net angular momenta of the three-particle system about these points, L_a , L_b , L_c and L_d , greatest first.

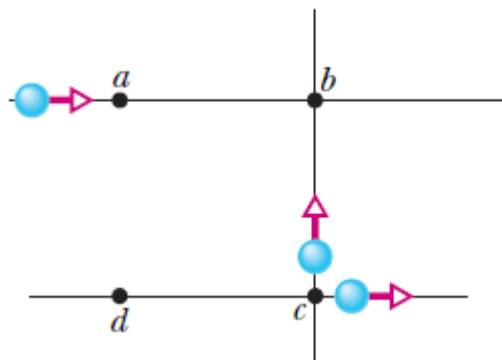

- A) L_a , L_b and L_c tie, L_d
- B) L_b , L_a and L_c tie, L_d
- C) All tie
- D) L_b , L_d , L_a and L_c tie
- E) L_d , L_a , L_c and L_b tie

Q20. **Figure 12** shows two disks A & B rotating in the same direction. Disk A has a mass of 2.00 kg, a radius of 0.200 m, and an initial angular speed of 50.0 rad/s. Disk B has a mass of 4.00 kg, a radius of 0.100 m, and an initial angular speed of 200 rad/s. The disks are pushed toward each other with equal and opposite forces acting along the common axis. Find the common angular speed after the disks are pushed together into contact.

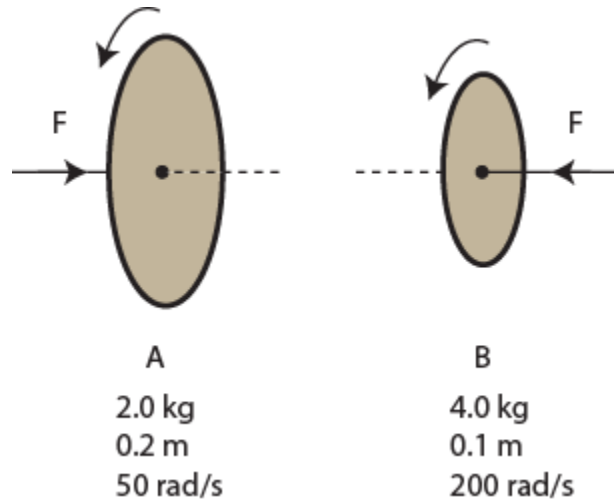

- A) 100 rad/s
- B) 120 rad/s
- C) 87.0 rad/s
- D) 95.0 rad/s
- E) 65.0 rad/s