

Q1.

A satellite of mass 1300 kg is rotating around the earth in an orbit of radius 0.665×10^7 m. Then the satellite moves to a new orbit of radius 4.230×10^7 m. What is the change in its mechanical energy?

- A) $+3.29 \times 10^{10}$ J
- B) $+2.53 \times 10^{10}$ J
- C) -1.65×10^{10} J
- D) -3.29×10^{10} J
- E) -2.53×10^{10} J

Q2.

A car has a velocity of 50 km/h along the positive x-direction for the first half of the distance and 75 km/h for the second half of the distance to the final destination. Calculate the average velocity for the entire distance.

- A) 60 km/h
- B) 80 km/h
- C) 90 km/h
- D) 50 km/h
- E) 40 km/h

Q3.

Vector $\vec{A} = -6.0 \hat{i} + 4.0 \hat{j}$. Find the magnitude of vector $\vec{B} = -2.0 \hat{i} + b \hat{j}$ if \vec{B} is perpendicular to \vec{A} ? [\hat{i} and \hat{j} are the unit vectors in the x and y-direction, respectively]

- A) 3.6
- B) 3.0
- C) -1.0
- D) 6.0
- E) -6.0

Q4.

A boat takes 3 hours to travel 30 km along the river flow, then 5 hours to return to its starting point. How fast, in km/h, is the river flowing?

- A) 2
- B) 8
- C) 6
- D) 4
- E) 9

Q5.

A constant force of 8.0 N is exerted horizontally for 4.0 s on a 16 kg object which is initially at rest on a horizontal frictionless floor. Find the final speed, in m/s, of this object.

- A) 2.0
- B) 0.5
- C) 32
- D) 4.0
- E) 8.0

Q6.

A 0.040 kg ball is thrown from the top of a 30.0 m tall building (point A) at an unknown angle above the horizontal. As shown in **Figure 1**, the ball attains a maximum height of 10.0 m above the top of the building before striking the ground at point B. If air resistance is negligible, what is the value of the kinetic energy of the ball at B minus the kinetic energy of the ball at A?

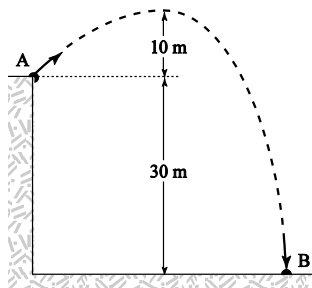

- A) +11.8 J
- B) -11.8 J
- C) +15.7 J
- D) -15.7 J
- E) +8.84 J

Q7.

A 0.2 kg billiard ball moving with a speed of 10 m/s along the + x-axis, approaches an identical ball at rest, as shown in **Figure 2**. The collision between the balls is elastic. After the collision the incident ball moves with a speed of 6.43 m/s at an angle of 50° below the + x-axis. The angle at which the target ball moves after the collision is:

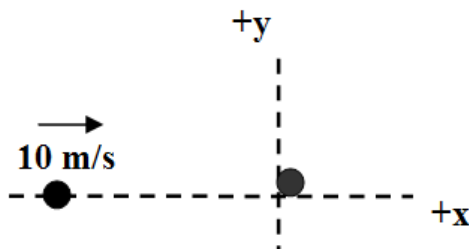

- A) 40° above the + x-axis
- B) 10° above the + x-axis
- C) 50° above the + x-axis
- D) 50° below the + x-axis
- E) 130° below the + x-axis

Q8.

In **Figure 3**, block 1 (mass 2.0 kg) is moving rightward at 9.0 m/s and block 2 (mass 4.0 kg) is at rest. The surface is frictionless, and a spring with a spring constant of 1120 N/m is fixed to block 2. When the blocks collide, the compression of the spring is maximum at the instant the blocks have the same velocity. Find the maximum compression, x_{\max} in meters.



- A) 0.31
- B) 0.60
- C) 0.22
- D) 0.17
- E) 0.01

Q9.

Figure 4 shows an object of mass 10 kg suspended by three ropes. Each rope supports an equal portion of the object's weight. The two end ropes make an angle of $\phi = 70^\circ$ to the horizontal. Find the tension, in Newton, in each of the ropes.

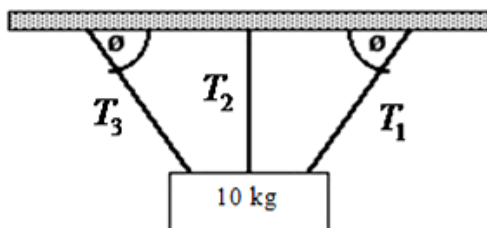

- A) ($T_1 = 34.8, T_2 = 32.7, T_3 = 34.8$)
- B) ($T_1 = 45.2, T_2 = 34.5, T_3 = 45.2$)
- C) ($T_1 = 10.4, T_2 = 32.7, T_3 = 10.4$)
- D) ($T_1 = 14.5, T_2 = 14.5, T_3 = 14.5$)
- E) ($T_1 = 21.6, T_2 = 32.7, T_3 = 27.8$)

Q10.

The positions of Earth, the Moon and the spacecraft are shown in **Figure 5**. At what distance " X " from the center of the moon will the gravitation pull from the moon be the same as the gravitational pull from the Earth? Assume that $M_e = 81 M_m$, where M_e is the mass of the Earth and M_m is the mass of the Moon. The distance from the center of the Earth to the center of the Moon is 3.8×10^5 km.

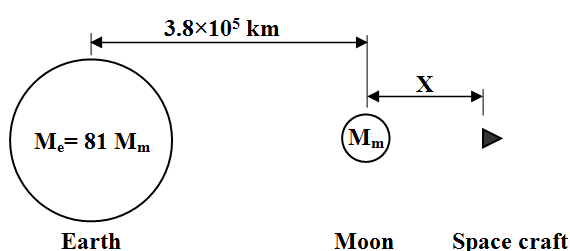

- A) 4.8×10^4 km

- B) 3.4×10^5 km
- C) 3.8×10^4 km
- D) 7.6×10^5 km
- E) 1.9×10^5 km

Q11.

Calculate the net torque (magnitude, in N.m, and direction) on a uniform beam shown in **Figure 6** about a point O passing through its center.

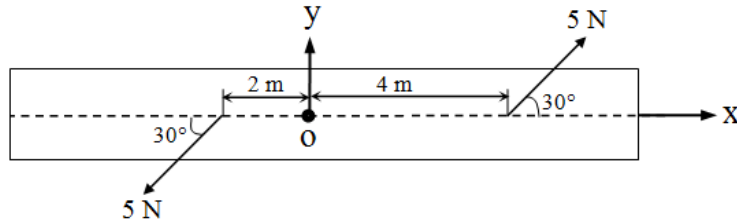

- A) $15 \hat{k}$
- B) $25 \hat{k}$
- C) $10 \hat{k}$
- D) $20 \hat{k}$
- E) $5.0 \hat{k}$

Q12.

Figure 7 shows three arrangements of four identical particles, with three of them placed on a circle of radius 0.20 m and the fourth one placed at the center of the circle. Rank the arrangements according to the magnitude of the net gravitational force on the central particle due to the other three particles, greatest first.

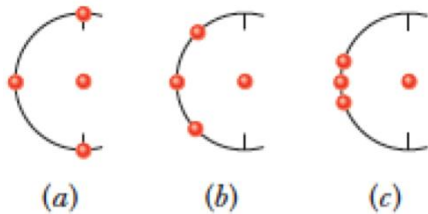

- A) c then b then a
- B) a then b then c
- C) all the same
- D) a then b and c tie
- E) c then a and b tie

Q13.

A satellite was launched from the ground with an initial speed v toward outer space. It reached a maximum altitude of 5 times the radius of Earth. Find v . [Ignore any air resistance]

- A) 1.02×10^4 m/s
- B) 9.99×10^4 m/s
- C) 5.00×10^4 m/s
- D) 4.56×10^4 m/s
- E) 2.04×10^4 m/s

Q14.

Both Venus and the Earth have approximately circular orbits around the Sun. The period of the orbital motion of Venus is 0.615 year, and the period of the Earth is 1 year. Find the ratio (R_E/R_V). [R_E is radius of the earth's orbit, and R_V is the radius of the Venus orbit].

- A) 1.38
- B) 0.72
- C) 4.29
- D) 2.64
- E) 1.17

Q15.

A cylindrical container has a layer of oil of thickness 0.120 m floating on water that is 0.250 m deep. The density of oil is 750 kg/m^3 . What is the gauge pressure, in kPa, at the bottom of the container?

- A) 3.33
- B) 0.882
- C) 2.45
- D) 1.27
- E) 6.35

Q16.

A physical pendulum consists of a uniform thin rod of length 1.00 m, of mass M , with a point object, of mass M , attached to its end, as shown in **Figure 8**. What is its period of oscillation about an axis pass through point **A**?

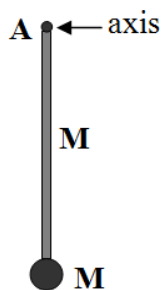

- A) 1.89 s
- B) 1.00 s
- C) 2.75 s
- D) 2.68 s
- E) 2.50 s

Q17.

A block of wood ($\rho = 850 \text{ kg/m}^3$) floats on water with a 50.0 kg person standing on top of the block (see **Figure 9**). What minimum volume, in m^3 , must the block have such that the top face of the block will be just in level with the water surface?

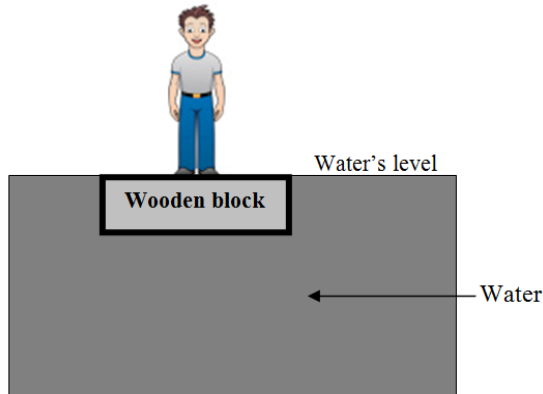

- A) 0.333
- B) 0.588
- C) 0.500
- D) 0.635
- E) 0.270

Q18.

Two cubes made of Lead and aluminum, having the same volume, are suspended at different depths in water by two wires, as shown in **Figure 10**. Wire 1 is used for lead and wire 2 is used for aluminum. If the densities are $\rho(\text{aluminum}) = 2700 \text{ kg/m}^3$ and $\rho(\text{lead}) = 11300 \text{ kg/m}^3$, which of the following statements is correct?

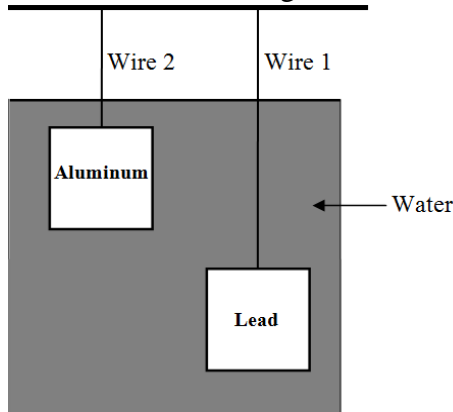

- A) The tension is larger in wire 1.
- B) The tension is larger in wire 2.
- C) The buoyant force is larger on the lead cube.
- D) The buoyant force is larger on the aluminum cube.
- E) The tension and buoyant force are the same for both cubes.

Q19.

Water flows through a horizontal pipe of variable cross-section. The pressure is 1.5×10^4 Pa at a point where the speed is 2.0 m/s and the area of cross section is A . Find the pressure, in Pa, at the point where the area is $A/2$.

- A) 0.90×10^4
- B) 0.60×10^4
- C) 0.30×10^4
- D) 1.30×10^4
- E) 1.60×10^4

Q20.

A tank is filled with water and a tightly fitting piston rests on top of the water. The combined pressure from the piston and atmosphere on the top surface of water is 1.02×10^5 Pa. A small circular hole is opened at a depth of 60.0 cm below the upper water level of the tank. What is the initial speed of water coming out of the hole?

- A) 3.71 m/s
- B) 7.13 m/s
- C) 1.37 m/s
- D) 5.31 m/s
- E) 2.17 m/s

Q21.

An object of mass m is attached to one end of a spring, with spring constant k , while the other end is fixed to a vertical wall. The object is oscillating on a horizontal frictionless surface. If the amplitude of the oscillations is A , find the maximum speed of the object.

- A) $A \sqrt{\frac{k}{m}}$
- B) $A \sqrt{\frac{m}{k}}$
- C) 0
- D) Am/k
- E) Am^2/k

Q22.

The displacement of an object oscillating in a simple harmonic motion is given by:

$$x(t) = x_m \cos(\omega t + \phi)$$

If the initial displacement is zero and the initial velocity is in the negative x direction, then the phase constant ϕ , in radians, is:

- A) $\pi/2$
- B) 0
- C) 3π
- D) π
- E) 2π

Q23.

A 0.25 kg block is attached to the end of a spring with a spring constant of 200 N/m. The system oscillates and has a total energy of 6.0 J. The maximum speed of the block is:

- A) 6.9 m/s
- B) 8.6 m/s
- C) 0.24 m/s
- D) 0.12 m/s
- E) 0.42 m/s

Q24.

A spring of force constant $k = 89 \text{ N/m}$ is attached vertically to a table (**Figure 11**). A balloon, with negligible mass, is filled with helium to a volume of 5.0 m^3 and is connected with a light cord to the spring, causing it to stretch. Determine the extension L when the balloon is in equilibrium. [$\rho (\text{air}) = 1.2 \text{ kg/m}^3$ and $\rho (\text{helium}) = 0.18 \text{ kg/m}^3$].

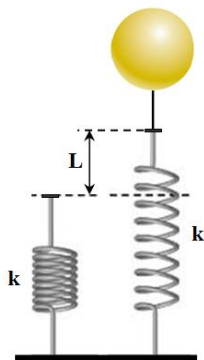

- A) 0.56 m
- B) 0.23 m
- C) 0.43 m
- D) 0.15 m
- E) 0.27 m

Q25.

A simple pendulum of length L and mass M has frequency f . To increase its frequency to $2f$, one should:

- A) decrease its length to $L/4$
- B) increase its length to $2L$
- C) decrease its length to $L/2$
- D) increase its length to $4L$
- E) decrease its mass to $M/4$